

AUTONOMOUS UNDERWATER VEHICLE TECHNICAL REPORT

DERRICK BROWN
DOMINIQUE CORRIVEAU
4/30/2005

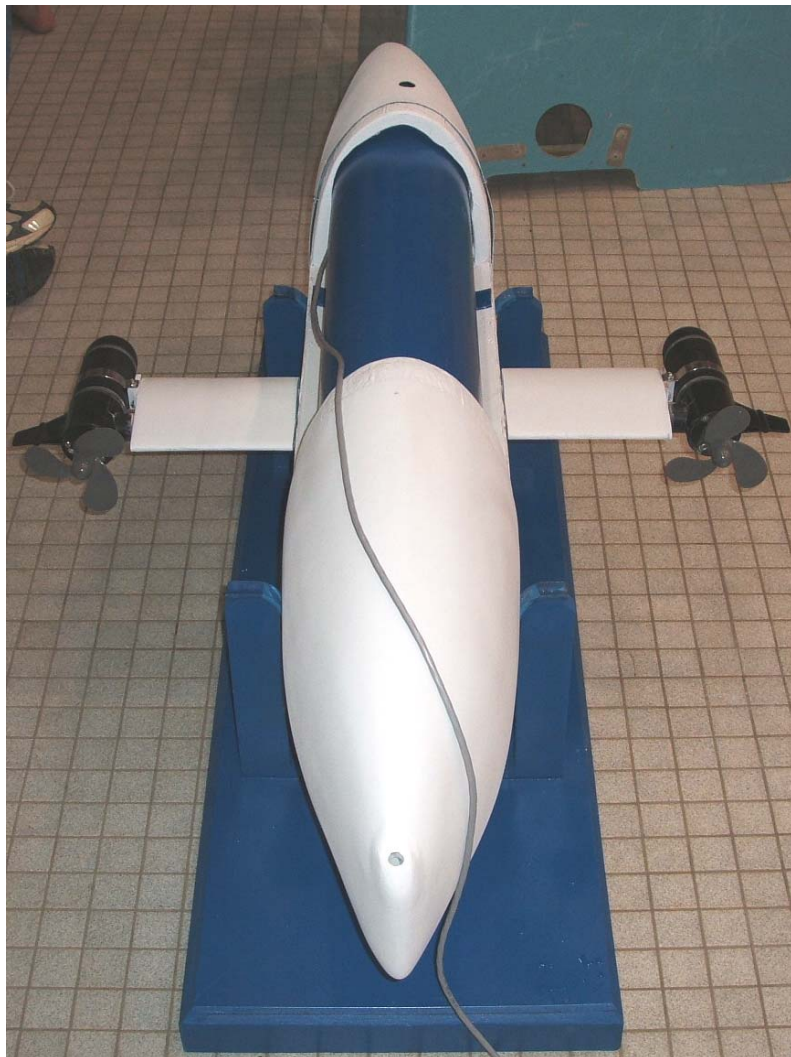

TABLE OF CONTENTS

Introduction.....	3
Design Approach.....	4
Warnings and Dangers.....	5
Drive Systems	
Vertical Thrusters.....	6
Primary Thrusters.....	7
Mounting and Adjustment.....	7
In Pool Results.....	8
Electronics	
Layout.....	10
Speed Controllers.....	11
Vantec RET411H Speed Controller.....	11
Serial Interface Board.....	12
Connections.....	12
PC 104.....	12
Connections.....	14
Capabilities and Modes of Operation.....	14
Example Program.....	15
Power System	
Batteries.....	16
DC-DC converter.....	17
Kill Switch.....	17
Through Hull Connectors.....	19
Optimization of Bilge Pump Jet Propulsion.....	20
Future Work.....	25

INTRODUCTION

The purpose of the Autonomous Underwater Vehicle is to eventually participate in the annual International Autonomous Underwater Vehicle Competition, sponsored by the Association for Unmanned Vehicle Systems International organization.

This competition is participated in yearly by engineering schools such as MIT, Cornell University, Virginia Tech, Duke University, University of Rhode Island, and many more.

The mission of the competition consists of several tasks that vary from year to year. The vehicles must be fully automated. There is no outside direction or control allowed whatsoever. Previous competitions have involved such tasks as:

- Reading barcodes
- Finding sonar pingers
- Finding LED lights
- Dropping markers onto designated targets
- Following directions marked on the bottom of the pool
- Steering through gates
- Submerging to depths of 16 ft
- Operating for 15 minutes on one battery charge

Due to the nature of the competition and the fact that rules change on an annual basis, the AUV must be designed with a certain amount of adaptability. This is especially true if a team is building the AUV with the intention of having it compete in competition for several years. Teams in the past have incorporated pressure transducers, photoelectric sensors and hydrophones. The complex nature of the AUV's mission makes it too large of a project to be designed in one year. This means that our group must make design decisions that will serve this year's group as well as address the needs of future groups.

The work of this year's team is to begin laying the groundwork that will allow future groups to have success in this competition. Specifically, our group's goal is to design and fabricate the vertical and horizontal drive systems, a watertight electronics compartment, and a basic computer driven control system. This report details the design and fabrication process that our group used to create a viable infrastructure for the AUV onto which future groups will build

DESIGN APPROACH

The autonomous nature of this competition has made it primarily an electrical and computer engineering competition. As a result of this, most teams' designs center on complicated electronics systems while neglecting hydrodynamics and simpler sensory systems. Our group recognizes that these trends open the door for an electronically simple and mechanically advanced submarine to do very well in the competition.

From a Hydrodynamic standpoint our submarine has a distinct advantage over other groups in the AUV competition because its hull design predates the design of the electronics systems. This is because we will be using a fiberglass hull designed by a previous year's team. Also our group benefits from a simple, robust and powerful propulsion system with only two exposed props. This system lowers the drag forces on the boat without sacrificing maneuverability.

Figure 1 shows a simplified diagram of the AUV. From this diagram it can be seen that many of the components of the AUV serve more than one purpose. The batteries for instance not only supply the AUV with power but they also lower the AUV's center of gravity. Similarly the location of the waterproof electronics compartment was chosen to raise the center of buoyancy. The efficient placement of these two components causes a righting moment that is sufficient to eliminate the need for a stability system for the AUV in the direction of roll. Figure 1 also shows the location of the AUV's electronics board, main thrusters, and the location of its vertical thrusting nozzles.

Simplified AUV Layout

(Side cutaway view)

(Main thrusters removed for clarity)

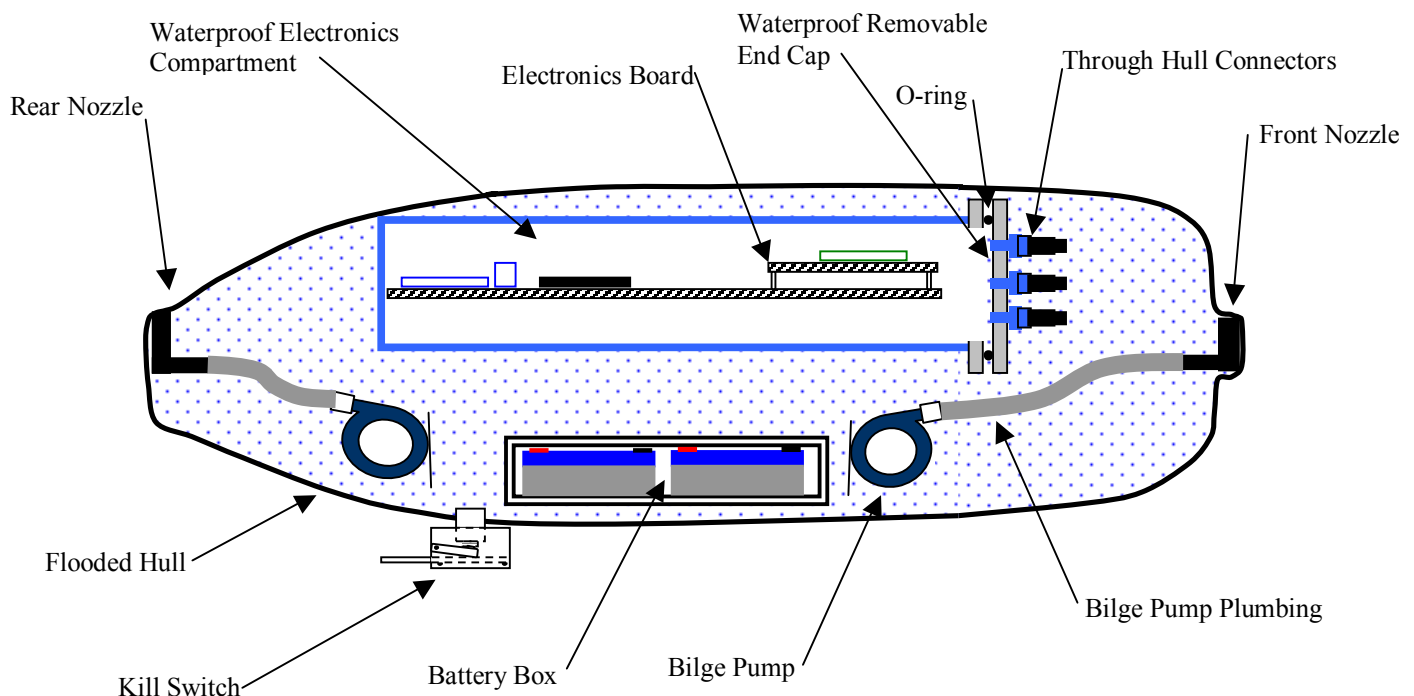

Figure 1

WARNINGS AND DANGERS

Although every attempt has been made to select safe and reliable hardware for the AUV there are still some potential dangers that could cause harm to the AUV or its operators. The following warnings and dangers should be considered whenever doing work on the AUV.

BATTERY HAZARDS

Although the batteries used on the AUV appear to be small they are capable of discharging up to 29 amps each in the event of a short circuit. This kind of current can destroy electronic devices and hurt or kill an operator. To avoid this potential harm the following precautions are considered important by the current AUV group.

- 1) Always make changes to the electronic and computer systems with the power disconnected and double check wiring before powering the circuit.
- 2) Always work on an appropriately fused circuit even if temporary fuses must be installed.
- 3) Always use a voltmeter to insure that wiring diagrams and pin outs are correct.

STATIC ELECTRICITY HAZARDS

Static electricity can damage many of the components on the AUV including the PC-104, speed controllers, and serial interface board. To avoid damaging these components avoid wearing synthetic clothing like fleece jackets while working on the AUV, and periodically touch a grounded component to avoid accumulating a static charge.

LEAKING HAZARDS

All of the major systems on the AUV include watertight seals. These seals must be properly installed and tightened to avoid infiltration of water. Silicone grease may also be applied to all of the O-ring and gland seals on the sub to further prevent leaks. Particular attention should be paid to the tightening of the bolts on the removable end cap. Operators should avoid tightening these bolts in a circular pattern. This could cause improper seating of the O-ring and could cause leaks.

DRIVE SYSTEM

The drive system for the AUV is designed to address the needs of the competition that it will eventually compete in. These rules require that the submarine must be at least 1% buoyant at all times during the competition. This rule necessitates that the submarine must have vertical thrusters that are capable of overcoming its positive buoyancy to sink the sub. The competitions other rules require that the sub must be highly maneuverable and capable of forward and reverse travel. Additionally the rules for the AUV competition give huge incentives for speed and reward competitors for building AUV's that are as light as possible.

Figure 2 shows the basic propulsion scheme for the AUV. This scheme was devised with the competitions rules in mind. This figure shows how vertical thrusters attached to the bow and stern can control the depth of the sub and also control the pitch angle. The main thrusters also shown in Figure 2 control the forward and reverse travel of the sub and also act to change the subs heading. Stability of the AUV is dictated by the distribution of weight and buoyancy inside the hull. By placing the evacuated electronics tube in the top center of the boat and all of the ballast for the boat in the bottom of the sub the need for a stability control system is avoided.

Basic Propulsion Scheme for AUV

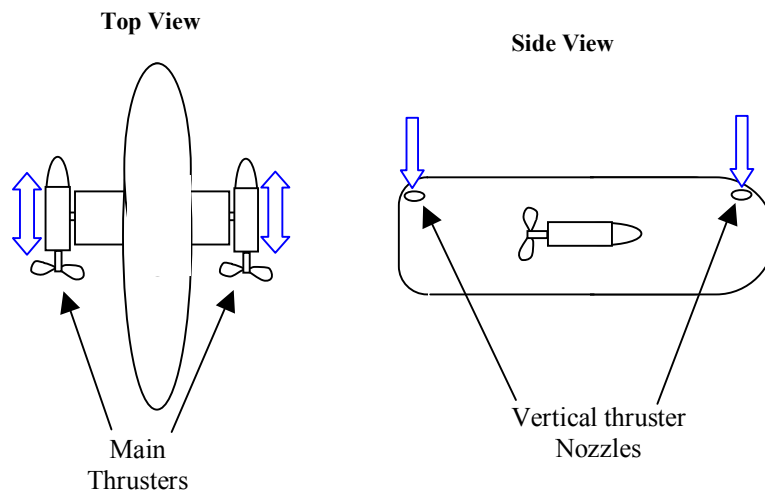

Figure 2

VERTICAL THRUSTERS

After extensive consideration a vertical thrusting scheme was devised that uses 750 gallons per hour bilge pumps for jet propulsion. To make this method of propulsion work the bilge pumps are mounted into the hull as shown in Figure 5, and nozzles are affixed to the stern and bow as shown in Figures 3 and 4 respectively. Thrust is generated when the pumps are turned on and water is sucked into the hull at low velocity through drain holes drilled in AUV's hull. This water is then accelerated in the pump and ejected out the nozzle at high speeds. For further information on the optimization of the nozzles see the section of this report labeled Optimization of Bilge Pump Jet Propulsion.



Figure 3



Figure 4



Figure 5

PRIMARY THRUSTERS

After considering many possible options for the primary propulsion of the AUV our group settled on modifying trolling motors to serve as the AUV's primary thrusters. Specifically we found that a trolling motor made by Sevylor called the Sevylor 29089 that is shown in Figures 6 and 7 fit our needs very well. This motor was selected because it was the smallest and lightest trolling motor available that would fulfill our thrust needs. Each trolling motor has a peak thrust of 14 pounds and will draw about 7 amps at full speed.

MOUNTING AND ADJUSTMENT

Because the trolling motors we selected were not originally intended to be mounted to an AUV some modification had to be made to allow for waterproofing and mounting the motors. Figure 6 shows a nylon shim that serves to both waterproof the motors power wires and to act as a pivot that allows for adjustment of the motor. This shim is epoxied into the motor housing and potting compound secures and waterproofs the power wires. Figure 7 shows how the remaining side of the motor is attached to the AUV's wings via an adjustable motor clamp. This clamp allows for the motors tilt to be precisely adjusted avoiding misalignments.

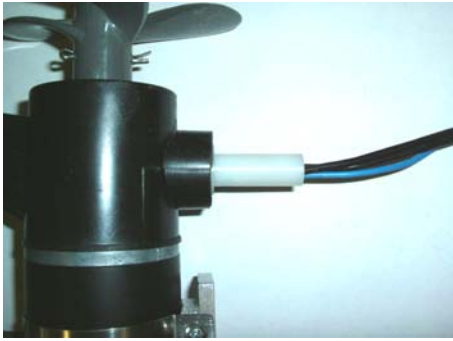

Figure 6



Figure 7

POOL TESTING RESULTS

All of the components of the drive system have been tested in a pool test. During this test the vertical thrusters were shown to have sufficient thrust to submerge the AUV. Also during this test the AUV's Primary motors were tested at high and low speeds. The result from this test showed that the AUV was capable of both fine control and high power. During another portion of the pool test the subs ability to make a sharp turn was tested with very good results. For video of the pool test visit our website that is found at http://www.umaine.edu/MechEng/Peterson/Classes/Design/2004_5/Groups/AUV/page1/welcome.html and click on the pool test icon.

ELECTRONICS

Our goal for this year was to have a computer and electronics system that could control the submarines onboard motors via a control signal from an onboard computer. This would allow us to program the computer to control the motors and test the hardware. We accomplished this goal with the use of the simple control scheme outlined in Figure 8. Figure 8 shows the hierarchy of the controllers used to maneuver the AUV. From this figure you can see that the control signal originates from the onboard computer which is of the PC-104 form factor. The computer then sends its signal through a serial cable to the serial interface board. Here the signal is interpreted into a signal that can be understood by the motor speed controllers. The motor speed controllers then generate the proper voltage for the motor power signal through the use of pulse width modulation. This power signal is then sent to the motor causing the motor to turn at the speed dictated by the onboard computer. The following sections will describe each component of this control scheme in more detail, and will show how each part is wired to control the AUV.

While learning about the function of each of the AUV's components special attention should be paid to the block diagram shown in Figure 9 and the layout picture shown in Figure 10. These Figures show the full layout of the AUV's electronics. Figure 9 shows how the electronics are distributed among two separate boards. These boards can be attached to each other with the mounting studs shown, or they can operate separately with a long serial connection between them. This ability to separate the boards when convenient allows for the possibility of umbilical control which is described in depth in the PC-104 section of this report.

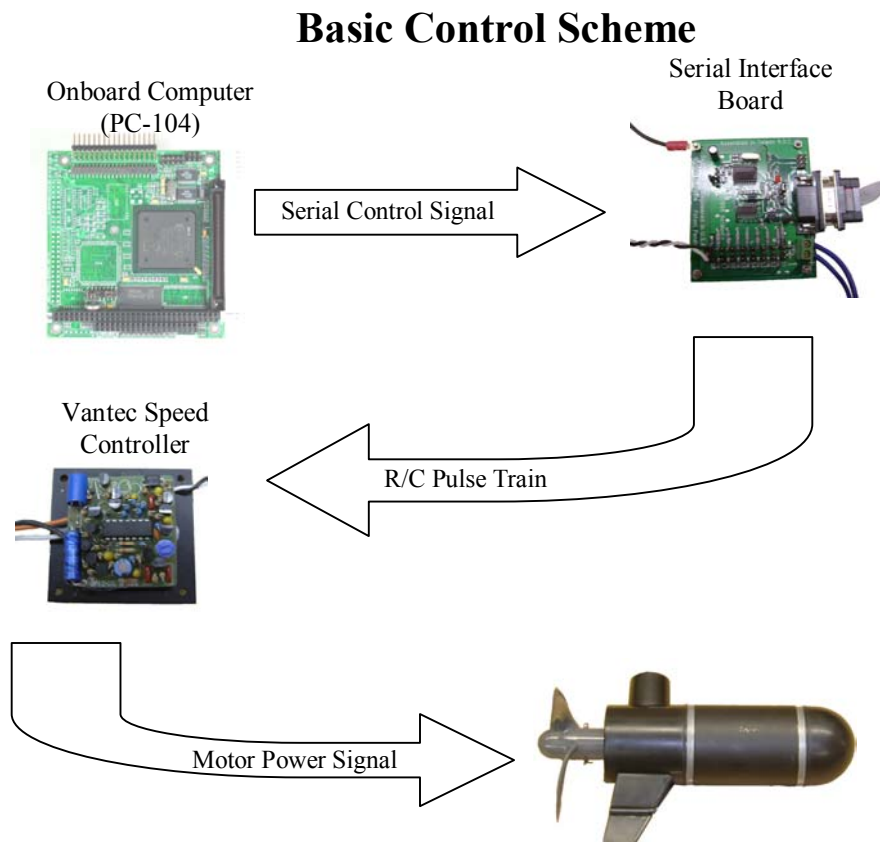

Figure 8

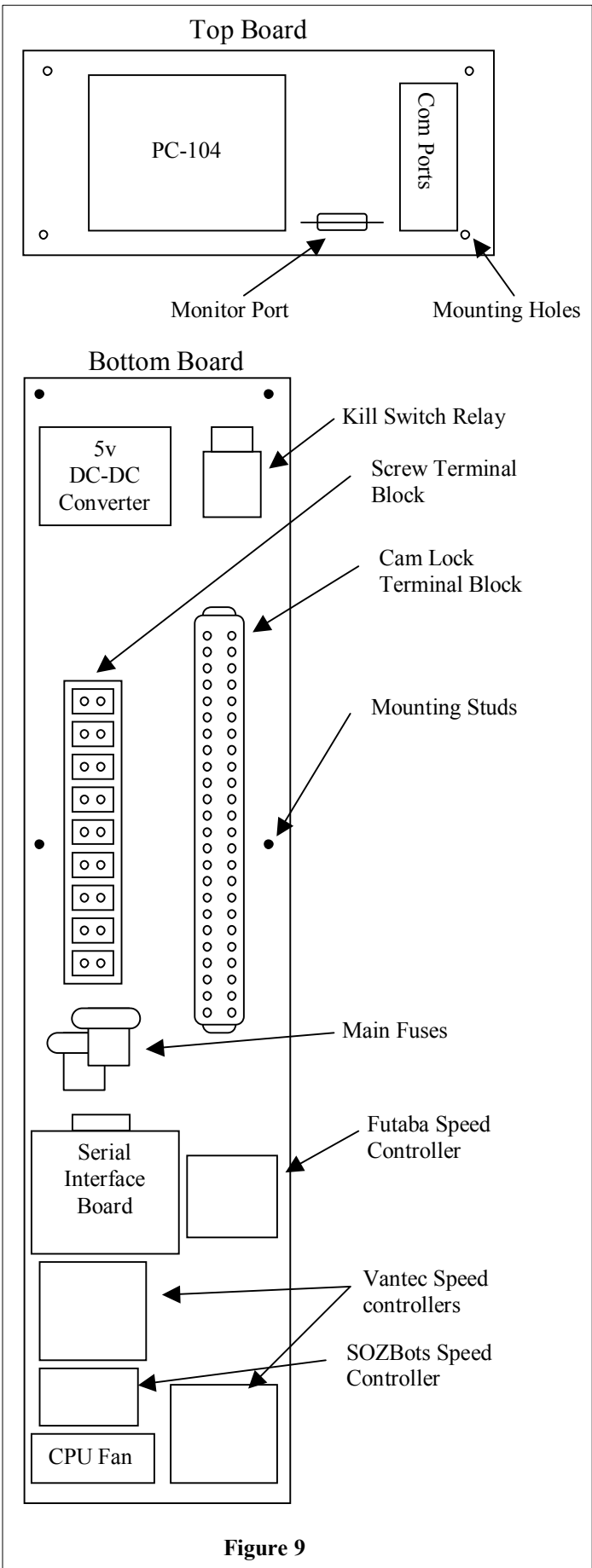

Figure 9

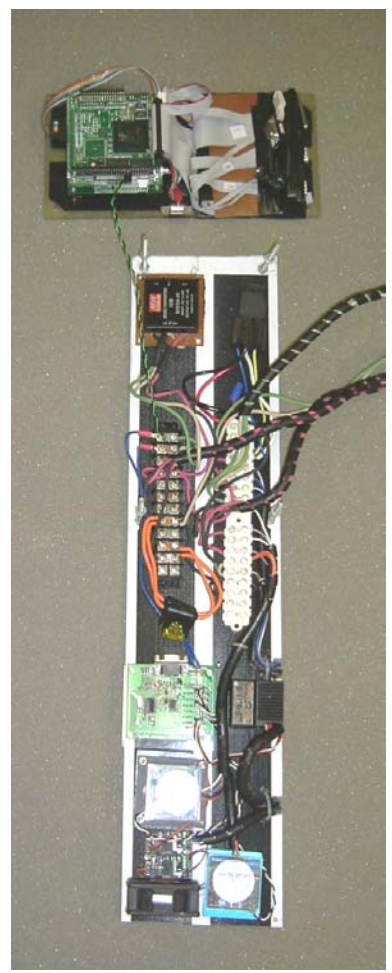

Figure 10

SPEED CONTROLLERS

In order to properly control the drive system of our AUV it is necessary to have a motor control system that is capable of proportionally and independently controlling the speed of the main and vertical thrusters. After considering many possible systems it was discovered that a system based around RC hobby motor controllers would meet our needs at the lowest cost possible without sacrificing benefits. These controllers use pulse width modulation to control the speed of the motors. Pulse width modulation or PWM is a method of speed control where the motor controller switches the current to the motor on and off at a very high rate. The ratio of time that the current to motor is on is then varied to produce effective speed control of the DC motor.

Figure 9 shows the three different types of RC hobby speed controllers that are currently used on the AUV. All of these controllers have very similar inputs and outputs, and they perform the same task. Because of this only the Vantec speed controllers will be described in depth in the following section of this report. This particular brand of motor controller has proven to be particularly robust and simple to use. It is the recommendation of this years AUV team that future groups should replace the other brands of speed controllers with identical Vantec units. This will make the AUV simpler to use and will make purchasing backup units easier.

VANTEC RET41 1H SPEED CONTROLLER

There are currently two Vantec RET411H speed Controllers on the AUV. Currently these units have the job of controlling the speed and direction of the AUV's main motors. This section of the report will describe how these Vantec units are wired into the AUV and will explain the control signals that make the Vantec units operate.

Figure 11 is a picture taken of one of the Vantec speed controllers onboard of the AUV. It can be seen from Figure 11 that the Vantec speed controllers each need six wires that are properly connected in order to operate. The first connection of interest is the black power wire. This wire should be connected to the negative terminal of the supply battery. This connection can be made through one of the terminal blocks on the bottom electronics board. Also to operate the orange wire must be connected to the positive terminal of the battery. For safety though this connection should be fused with a 20A fuse to protect from accidental overdrawing of the battery in the case of a short circuit. This wire should be also connected onto a screw terminal that is switched by the kill switch relay. This relay allows the power to be disconnected from the motor controllers in the event that the AUV gets out of control. More information on the kill switch can be found in that power systems section of this report.

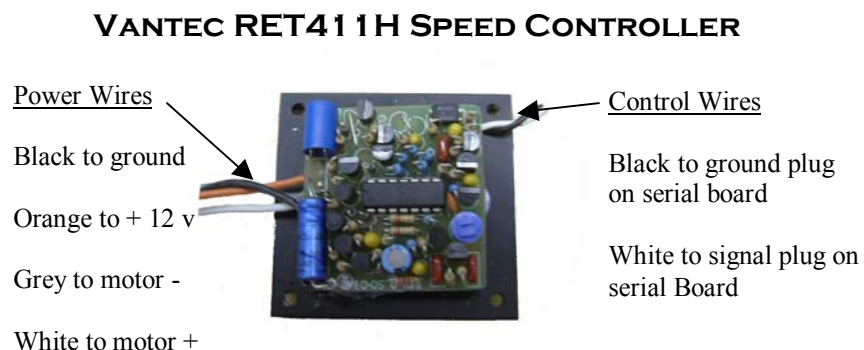

Figure 11

The remaining two power wires should be connected to the motor that the Vantec unit is to control. These connections should be made to the positive and negative terminals on the main thrusters via one of the terminal blocks. The correct polarity of these connections ensures that the motor turns in the direction that is transmitted to the Vantec from the onboard computer.

The speed and direction of the motor connected to the Vantec unit is dictated by a signal transmitted through the white and black control wires shown in Figure 11. These control wires are easy to connect because they terminate into a plug that fits directly into the serial interface board described in the next section of this report. The signal that is supplied to these wires by the serial interface board is called a servo pulse train and it is a digital signal that ranges from 0 to 255. Each of these numbers represents a separate speed setting with 255 being full forward and 1 being full reverse. For more information on the generation and meaning of this control signal see the next section of this report.

SERIAL INTERFACE BOARD

Once the Vantec speed controllers were selected it became necessary to find a reliable way of generating the servo pulse trains that control them. After looking at many ways of generating these signals including direct generation using the onboard computer a serial interface board made by Netmedia was found to be the best solution. This serial interface board is called the Servo 8 Torque Board by Netmedia and a picture of that board is pictured in Figure 12. The function of this board is to receive the speed settings of the motor controllers from the onboard computer through a serial connection and convert them to servo pulse trains via its onboard circuitry. These servo pulse trains are then sent through the motor controllers control wires to the motor controller boards where they affect the motors speed.

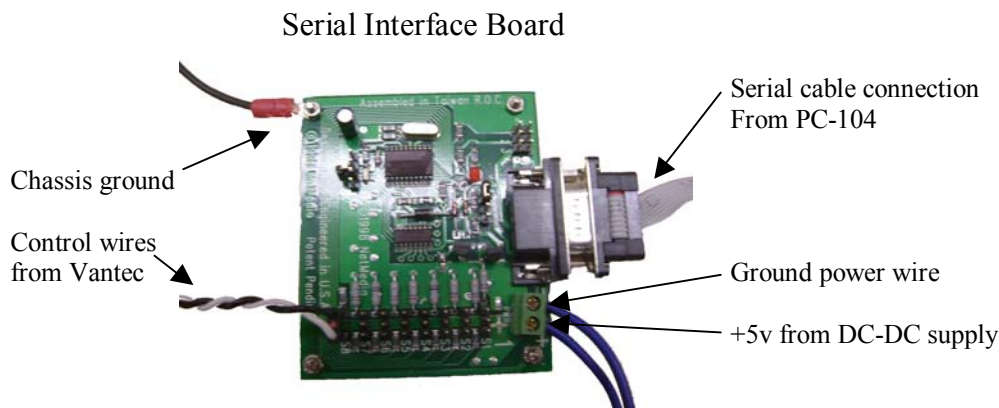

Figure 12

CONNECTIONS

Figure 12 shows the various connections that are needed to make the serial interface board function for the AUV. The first two connections made are the power connections that are made to the positive and negative 5v terminals of the DC-DC converter. For more information about the DC-DC converter see the correspondingly labeled section of this report. One important thing to note about the power connections for

the serial interface board is that they are not affected by the removal of the kill switch. This makes it possible to continue to program the serial interface board after the kill switch has been pulled. In the event that the AUV gets out of control this means that you can pull the kill switch to cut the power to the motors but you can continue to reset the motor controllers with the serial interface board so that the motors will not be on when the kill switch is reinstalled.

Figure 12 shows how the serial interface board also has a serial port plug. The serial cable from the PC-104 should be installed here. The cable can be run directly from the PC-104 with the use of a serial port gender changer or the long waterproof serial cable can be used for umbilical control. The capabilities and example program section of this report will describe the serial commands that can be sent to the serial interface board. Figure 12 also shows the chassis ground wire that is installed onto the serial interface board. This wire is simply a precaution that protects against static discharge. When the serial interface board is being worked on in the lab this wire is connected to the ground of a power supply to protect against damage from static electricity. When the board is installed in the AUV this wire is removed.

The final connection to the serial interface board is made by connecting the control wires from the speed controllers to the plugs that are shown in Figure 12. The speed controllers come from the factory with these pugs installed so the operator of the AUV must only be careful to install the plug with the white wire in the proper direction as shown in Figure 12. One control plug must be installed from each of the four motor controllers on the AUV. When installing the control pugs from the motor controllers note the number printed on the board next to the plug. This number will be important when sending control signals to the board.

PC-104

The PC-104 is the computer brain of the AUV. The term PC-104 refers to the size and configuration of the computer. The name of our PC-104 is the Prometheus LC and it is made by Diamond Systems. This computer is pictured in Figure 13. Although the PC-104 looks unlike most computers it actually functions much like a normal computer once the proper connections are made. The PC-104 has a processor speed of a 486 MHz and has connections for all of the normal computer accessories such as a keyboard and mouse. Additionally a video card attachment was purchased and installed on the PC-104 to allow the use of a standard computer monitor with the PC-104.



Figure 13

CONNECTIONS

The PC-104 has all of the standard connections that a person would expect to find on a computer motherboard. These connections are usually in miniature form though. The PC-104 has connections for floppy drives and hard drives as well as Ethernet connections and many more. The PDF manual that is provided by Diamond Systems and that is attached to this report does a very good job of describing how to make the proper connections to the PC-104. For the remainder of this report it will be assumed that proper interconnection of components to the PC-104 will be made with aid of the PC-104 manual.

CAPABILITIES AND MODES OF OPERATION

Eventually the PC-104 will help guide the AUV through the annual International Autonomous Underwater Vehicle Competition. In order to do that it will need a sophisticated operating and control system. Currently though the PC-104 is used only to test the drive system of the AUV and to prove that the selected electronics hardware is compatible. To do this a system has been developed that allows the PC-104 to operate either through an umbilical control tether or as a preprogrammed onboard controller.

In most cases the PC-104 will ride onboard the AUV in the waterproof electronics tube. For the purposes of testing hardware though this is not convenient because this eliminates the possibility of programming new hardware on the fly during a pool test. To avoid this drawback a control tether has been constructed which allows the PC-104 to stay poolside while the AUV is in the water. Programs can then be written on the PC-104 while active pool testing is taking place. The control tether is essentially a 45 foot long serial cable that is made out of waterproof cable. At one end of this cable is a waterproof connector like those shown in Figures 18 and 19. The other end of the cable is a standard serial cable connector that is attached to the PC-104. Inside the waterproof electronics tube the command tether is connected to the serial interface board. This allows the AUV to be operated up to 45 feet away from the PC-104.

In order for the PC-104 to act as a preprogrammed onboard controller a QBasic program like the one in the following section must be written to control the onboard motors. This program is then compiled into a stand alone executable and is copied onto the flash storage drive of the PC-104. A DOS operating system is also installed onto this flash drive. This allows the PC-104 to be capable of running the executable version of the QBasic program after only making +5v, ground, and serial connections to the PC-104. This means that the PC-104 board can be mounted onto the mounting studs shown in Figure 9 and the whole electronics board including the PC-104 can ride inside the waterproof electronics tube.

The umbilical and preprogrammed controller modes of operation that are currently possible with the PC-104 are limited to testing the AUV's drive systems and hardware. In order for the next step to be taken with the AUV new ways of utilizing the PC-104 will need to be found. Some possible ways that this could be done are discussed in the future work section of this report.

EXAMPLE PROGRAM

This program is written in the QBasic programming language. The program is designed to be run on the PC-104 and it assumes that the PC-104 is connected to the serial interface board through the comport #1 of the PC-104. In this programming language all lines that begin with a coma are considered to be comments and are ignored by the program. The comments are to help the user better understand what the program's commands are doing. For further visual aid the commented text is shown here in green. Also note that a zip file containing a QBasic compiler is included with this report.

```

.....
' This example program assumes the following: 1) Com1 of the PC-104 is connected to the serial interface board.
' 2) The right thruster's motor controller is connected to plug #2 on the serial interface board. 3) The left thruster
' is connected to plug #4 on the serial interface board. 4) The bow and stern bilge pumps are connected to
' plugs 7 and 8 respectively on the serial interface board.
.....

```

CLOSE

' This command closes any comports that may have been opened by other programs.

OPEN "COM1:19200,N,8,1,CD0,CS0,DS0" FOR RANDOM AS #1

' This line opens serial port 1 for input or output. It also sets the baud rate for the serial port to 19200.
' This line also assigns the comport the # 1 as a reference number for writing.

PRINT #1, ">"; "1"; "2"; "a"; CHR\$(255);

' This line shows how the PRINT #1 statement can be used to write data out of the serial port.
' This print command sends the following 5 bytes out of the comport.
' 1) The ">" is sent as a header to tell the serial interface board that data is coming.
' 2) The "1" is sent to identify the serial interface board, this command is needed because more than one board
' can be used in some applications.
' 3) The "2" tells the serial interface board that the signal is intended for the motor controller connected to the
' #2 plug on board. In this case that is the right main thruster.
' 4) The "a" is a command that turns on the indicated motor controller and sets the speed.
' 5) The CHR\$(255) is the speed setting for the motor controller. 255 = full forward, 1 = full reverse, 127 = stop,
' 0 = turn off motor controller and set speed equal to full stop

SLEEP 10

' This command stops the programs execution for 10 seconds. In effect this keeps the right motor on for 10 sec.

PRINT #1, ">"; "1"; "4"; "m"; CHR\$(0); CHR\$(180); CHR\$(0); CHR\$(180); CHR\$(0); CHR\$(0); CHR\$(255); CHR\$(255);

' This line is the same as the first print line except for the use of the "m" command. This command updates all
' all of the motor controllers with a new speed setting. The eight speeds for the motor controller plugs on the
' serial interface board are given in order followed by semi colons. Here the right motor and the left motor are
' set to a mid speed forward setting and the bilge pumps are both turned on full forward.

SLEEP 10

' Again execution is stopped for 10 seconds

PRINT #1, ">"; "1"; "4"; "m"; CHR\$(0); CHR\$(0); CHR\$(0); CHR\$(0); CHR\$(0); CHR\$(0); CHR\$(0); CHR\$(0);

' This command stops and shuts off all of the motors. Here a CHR\$(0) command is used instead of a
' CHR\$(127) command. This is the preferred way to stop a motor. This eliminates the possibility of
' the motor controller sending out a small voltage signal to the motor because of center drift in the
' motor controller. In practice anytime that a motor needs to be stopped a CHR\$(0) command should be used.

END

' This command stops execution and returns the user to the compiler or the operating system.

POWER SYSTEMS

In order for the AUV to be able to fulfill its autonomous mission a power source and delivery system had to be designed. This system had to be watertight, small, and have adequate power to drive the AUV. Additional modifications were needed to make sure that the system was safe to operate and that power could be delivered to the sensitive electronics equipment onboard the AUV. The following sections outline the individual components of the power system that was designed and fabricated for the AUV.

BATTERIES

In order to find the proper battery type and capacity for the AUV extensive research was done. The goal was to find a battery solution for the AUV that could handle the full draw of the AUV's motors (about 12A) for at least half an hour. This discharge would give about one and a half hours of runtime under normal operating conditions. After researching many possibilities a system that utilized four 12v PS-1229 batteries made by power sonic was selected. These batteries are of the sealed lead acid type, and they utilize absorbent glass mat technology. This technology makes the batteries maintenance free and it makes the batteries safe to use even if they are tipped upside down.

Figure 14 shows the waterproof container that was fabricated to house the four PS-1229 batteries. The waterproof box is fabricated from half inch acrylic that has been solvent bonded. The hinged top for the battery box is modified from a model 9000 Otterbox which has been cut in half to serve as the watertight door for the battery box. Figure 14 also shows the waterproof connections that are made through the Otterbox top. Two waterproof connections were needed for the battery box to keep the current traveling through the battery box cables within the cable manufacturer's acceptable limits.

Inside the battery box the batteries are wired in parallel in two groups of two. Each of the two groups is then wired to one of the waterproof connectors located on the Otterbox top. Two waterproof cables are then attached between the battery box and the electronics compartment's waterproof flange. Each of these cables carries half of the batteries current into the waterproof electronics compartment. Inside the waterproof electronics compartment the two battery cables are connected to shared terminals on the screw terminal block. The end result of this wiring scheme is that the four batteries are wired together in parallel without drawing too much current across the battery cables. This arrangement gives about 12 amp hours of combined capacity at 12v. Through testing this had proven to be enough capacity to power the AUV for a two hour pool test with plenty of reserve power.

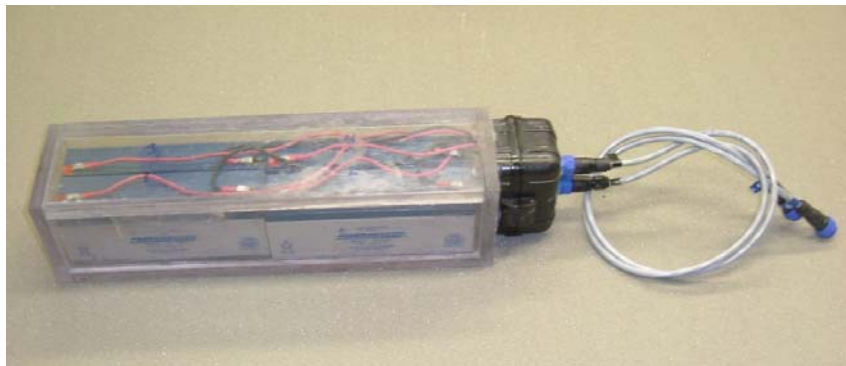

Figure 14

DC-DC CONVERTER

Both the PC-104 and the serial interface board need clean 5v power supplies to operate. Since the voltage from the batteries is 12v this means that some type of voltage converter is needed. For our proposes the simple DC-DC converter pictured in Figure 15 that is made by MEAN WELL has met our needs very well. This converter takes the 12v signal directly from the screw terminal board and through its internal circuitry it changes the voltage to a steady clean 5v signal. This converter is very important to the AUV not only because it creates the voltage needed to run the PC-104 and the serial interface board, but also because it protects these components from the voltage spikes that could be caused by the motors.

The connections that are needed for the DC-DC converter are made by mounting the converter onto a breadboard and soldering wires to the appropriate pins. The converter only has four pins on it. The first of these pins is the positive input pin. This pin is connected to the screw terminal board where the positive battery connections are made. Similarly the negative input pin is connected to the negative battery screw terminal. It is important to note that by connecting the DC-DC converter directly to the 12v power terminals on the bottom electronics board the kill switch is avoided. This means that any electronics powered by the DC-DC converter will remain powered after the kill switch is removed. This reduces possible damage to the delicate electronics that frequent shutdowns could cause. The final connections made to the converter are the positive and negative output connections. These connections are made to the cam locking terminal strip. This provides an easy attachment point to connect the PC-104 and the serial interface board to.



Figure 15

KILL SWITCH

In order to have a diver interact with the AUV while it is in the water it is important to have a way for the diver to disable the AUV if it gets out of control. To accomplish this a kill switch and relay system was developed that disables the AUV's when a safety key is removed. A simplified schematic of this system is shown in Figure 16.

Figure 16 shows how a 40A relay and a momentary switch combine to make the kill switch work. When the momentary switch shown in the figure is depressed a small current is allowed to flow from the positive to the negative battery terminals via the blue and yellow wires of the relay. This small current flowing through the relay causes a magnetic reed switch to be actuated inside of the relay. The actuation of this reed switch completes the connection between the positive battery terminal and the motor controller thereby powering the motor controllers. Conversely, if the momentary switch is not depressed no current flows through the relay and the motor controllers don't receive any power.

Kill Switch Diagram

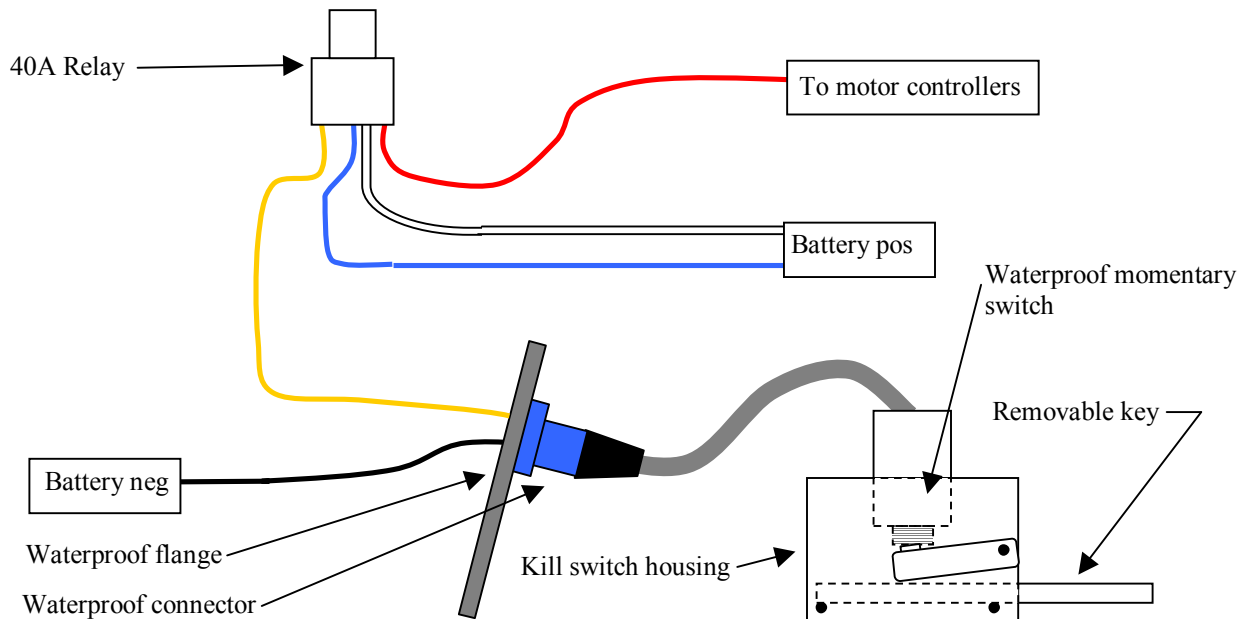

Figure 16

The momentary switch in Figure 16 is made into an effective kill switch through the introduction of the kill switch housing and removable key shown in Figures 16 and 17. This kill switch housing uses a lever to depress the momentary switch whenever a removable key is inserted into the kill switch housing. Figure 17 shows how a pull cord is attached to the removable key to facilitate fast removal of the key. This arrangement allows a diver to disable all of the AUV's motors by simply pulling the removable key's pull cord. A final benefit of this style of kill switch is that because a momentary switch is used the AUV would shutdown in the event that the kill switch housing was to fail.

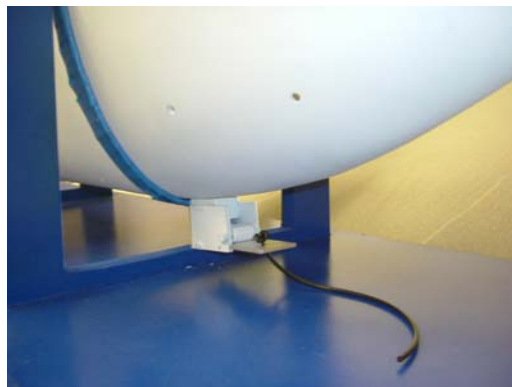

Figure 17

THROUGH HULL CONNECTORS

In order for the AUV to be as easy to use and durable as possible a reliable way of making through hull connections was needed. After looking into many industrial through hull solutions a waterproof connector system made by Bulgin systems was chosen. This system can be seen in application in Figures 18 and 19. This system has proven to be very cost effective and also very durable. This connection system consists of two parts a male plug, and a female bulkhead connector.

The male plugs used on the AUV are from Bulgin's 400 Series Buccaneer line. Specifically we selected a 3 pin 8A connector that accepts cables sizes up to 6mm in outside diameter. Bulgin's part number for this product is PX0410/03P/5560. This connector has an IP-68 rating and is additionally rated for two weeks of submersion at ten meters. These specifications meet and exceeded our normal current and draw and waterproofing needs. Because the Bulgin plugs that we selected use a cable gland seal to achieve water tightness a compatible cable needed to be found. For a compatible cable we chose a cable made by DEARBORN with a manufactures part number of 881803-100. This is an 18AWG cable that is compatible with our connectors. The cable has a water resistant PVC jacket and is capable of carrying sufficient current.

Originally our group had specified a bulkhead connector from Bulgin components with a part number of PX0412/03S to be used for the connection between the waterproof plugs and the watertight electronics compartment. Our group had supply problems with the company though that forced us to make a second choice for our bulkhead connectors. To get around our supply problems we decided to modify a compatible inline connector with a part number of PX0411/03S/5560 to serve as a bulkhead connector. This modification involved permanently epoxying the necks of the inline connectors through the watertight end cap. The result of this modification can be seen in Figure 18. In the end this solution proved to be at least a durable and every bit as functional as the part that was originally specified.



Figure 18



Figure 19

OPTIMIZATION OF BILGE PUMP JET PROPULSION

OBJECT

The purpose of the following experiment is to determine the nozzle diameter that will maximize the thrust produced by a submerged bilge pump.

APPARATUS, EQUIPMENT, AND EXPERIMENTATION

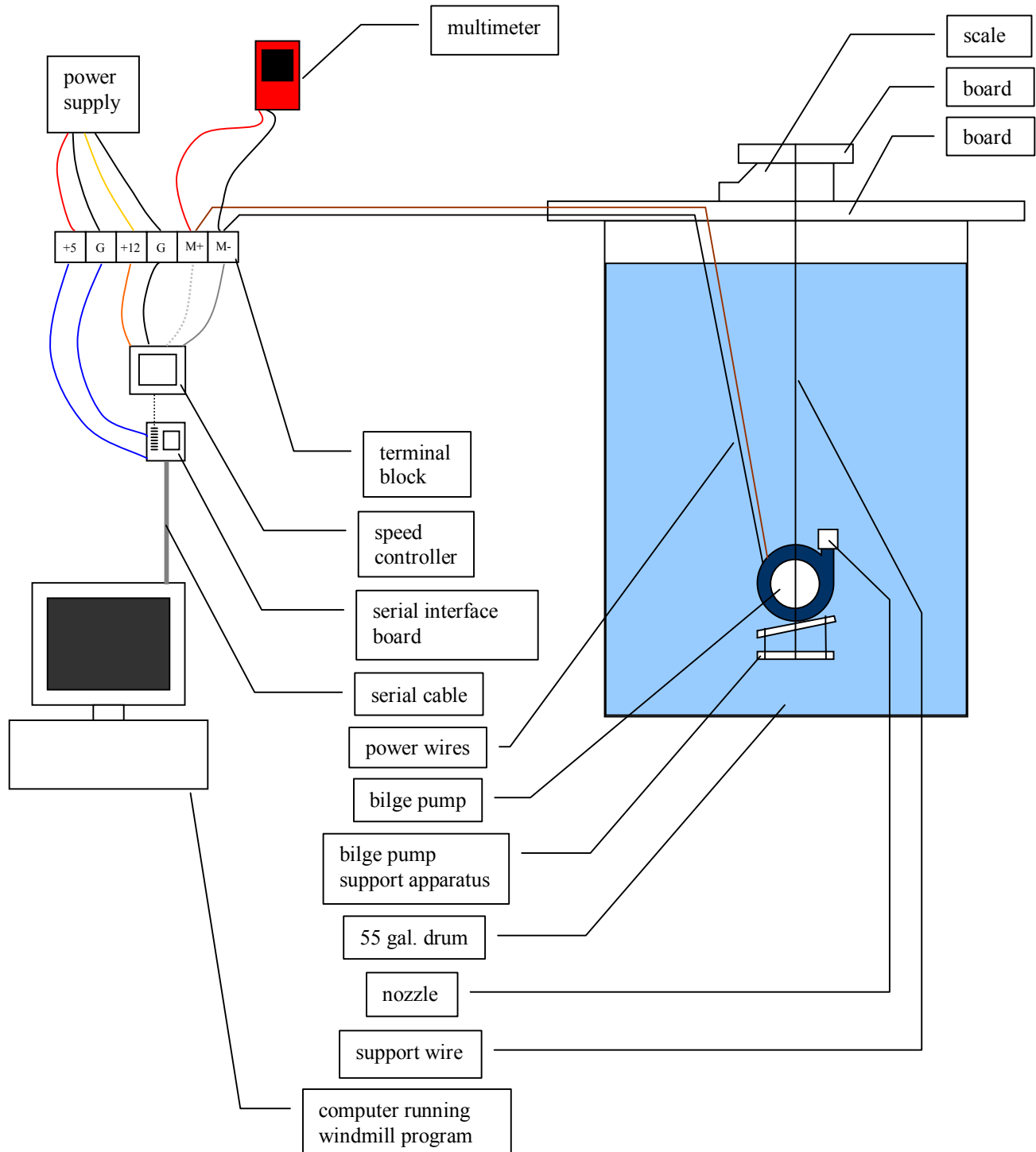

Figure 20

SETUP AND PROCEDURE

The steps to set up the experiment are as follows:

- Make the nozzle array:
 - $\frac{1}{4}$ "
 - $\frac{5}{16}$ "
 - $\frac{3}{8}$ "
 - $\frac{7}{16}$ "
 - $\frac{1}{2}$ "
 - $\frac{5}{8}$ "
 - $\frac{3}{4}$ "
- Make a bilge pump support apparatus so that the jet flows directly upward
- Fill $\frac{3}{4}$ of the 55 gallon tank with water
- Place the board across the rim of the tank
- Place the scale on the board
- Place a board on the scale and hang the support wire to the bilge pump apparatus from it
- Zero the scale
- Wire the terminal block
 - +5V and ground wires from power supply to appropriate serial interface board wires
 - +12V and ground wires from power supply to appropriate motor controller wires
 - M+/M- wires from motor controller to appropriate bilge pump wires and multimeter
- Wire the servo controller to the serial interface board
- Connect the serial interface board and the computer with a serial cable

The steps to perform the experiment are as follows:

- Always make sure the scale reads zero when the bilge pump is off
- Open the windmill program on the computer and fill in the necessary fields
- Send the servo the following signals:
 - 175
 - 195
 - 215
 - 235
 - 255
- Record the voltage and amperage displayed by the multimeter and the force displayed by the scale for each signal
- Attach the nozzles to the bilge pump and repeat the procedure for each one

RESULTS

The following graphs illustrate the data that resulted from this experiment.

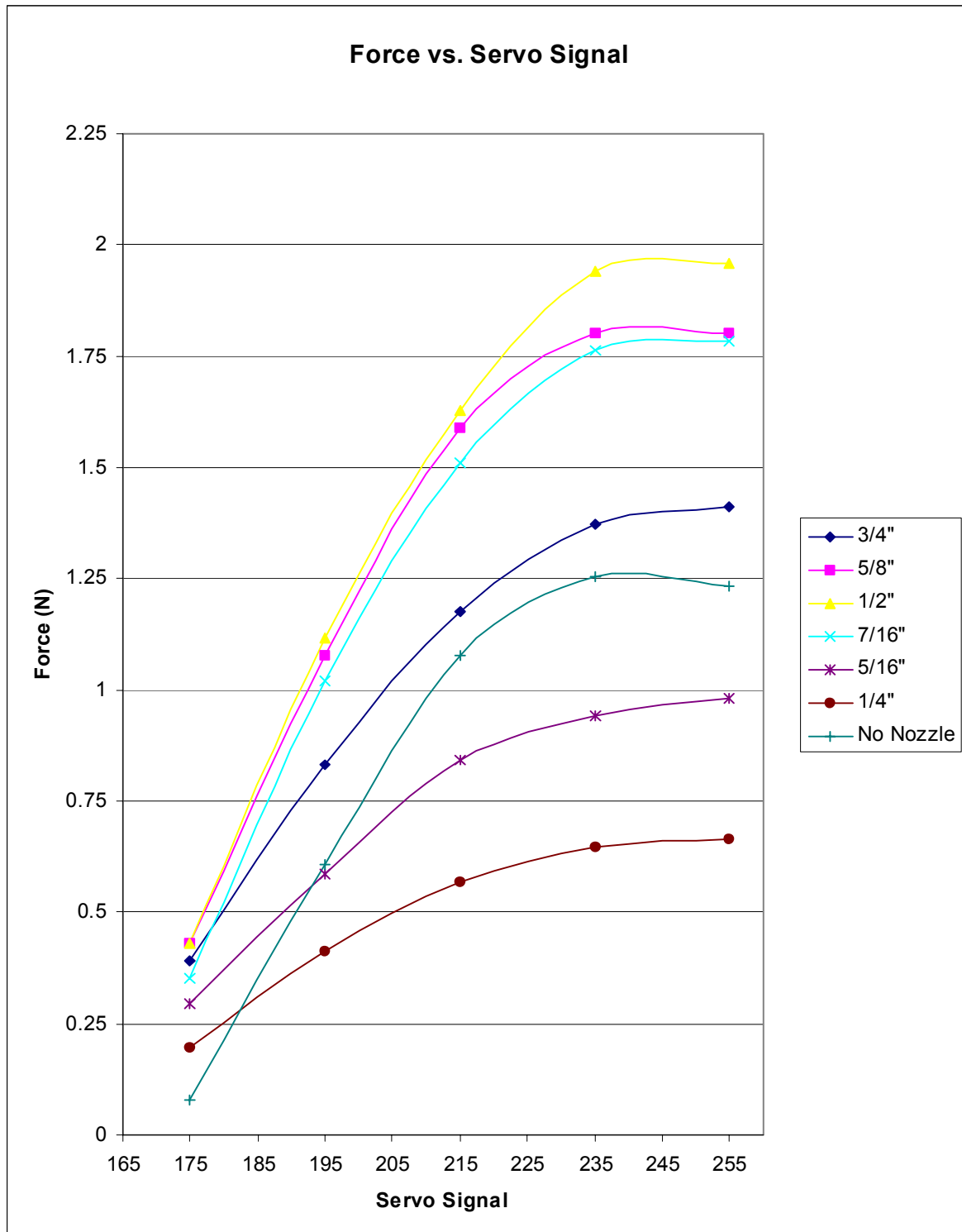

Figure 21

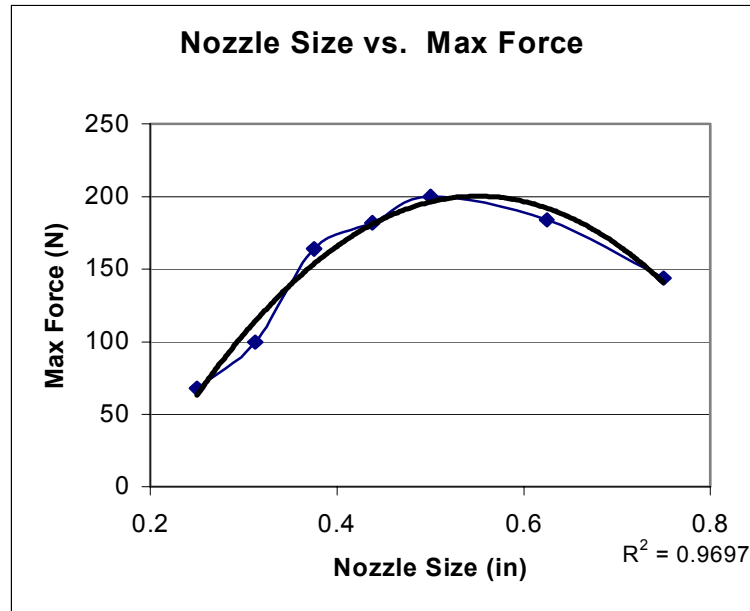

Figure 22

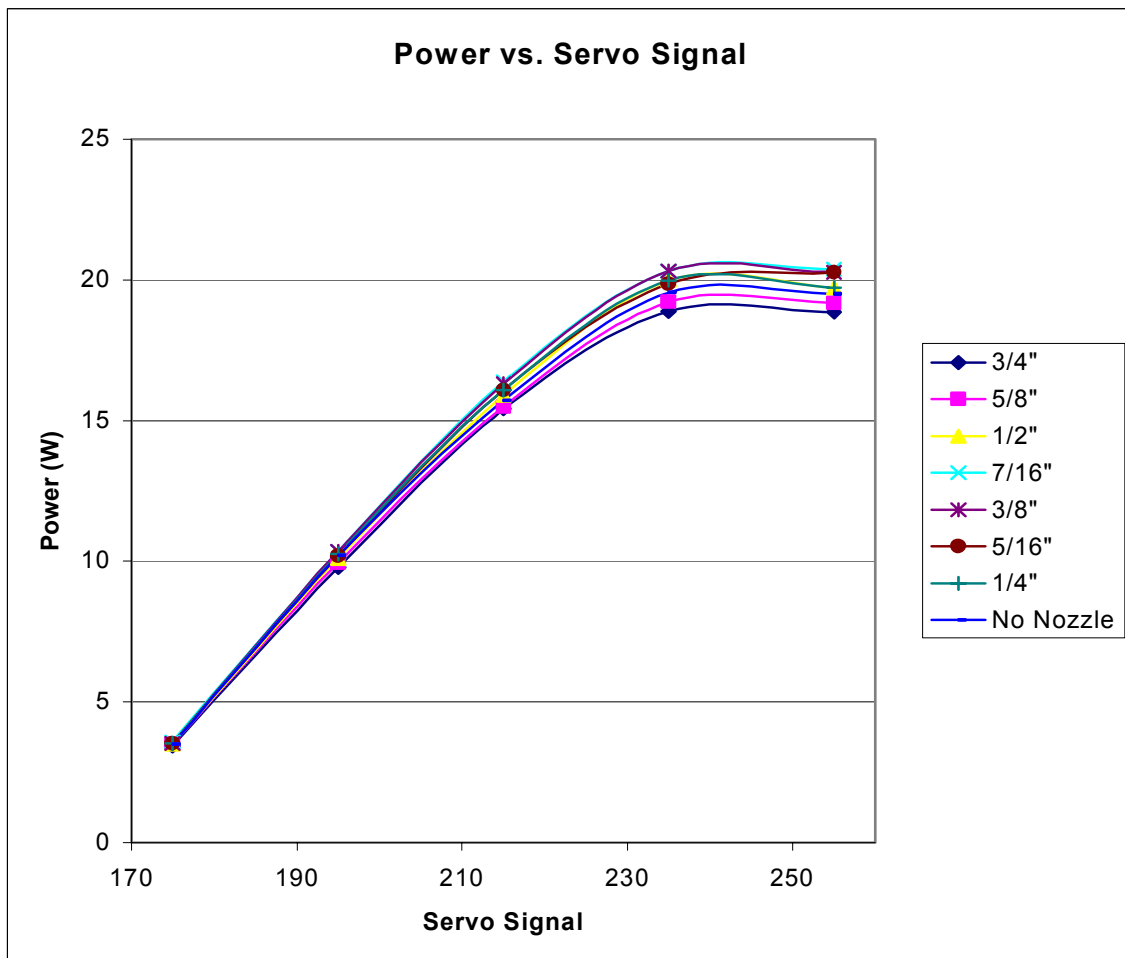

Figure 23

CONCLUSIONS

The Figures 21 and 22 show that the nozzle that maximizes the thrust of the bilge pump is the $\frac{1}{2}$ " nozzle. Figure 21 shows that the stock nozzle on the bilge pump only puts out about 60% of the thrust that the $\frac{1}{2}$ " nozzle does. The experiment was therefore worthwhile. Also, even though the $\frac{1}{2}$ " nozzle yields the maximum thrust Figure 23 shows that it doesn't take more power than the other nozzles did. In fact, while all the nozzles drew close to the same amount of power, the $\frac{1}{2}$ " nozzle fell about in the middle of the array.

This experiment shows that by installing $\frac{1}{2}$ inch nozzles on the AUV we can double the thrust produced by the pumps and achieve a very acceptable vertical thruster system. This experiment lead our group to fabricate and install the proper sized nozzles for the AUV.

FUTURE WORK

The following are recommendations made by this years AUV team to future groups. These recommendations are the result of a years worth of work with the AUV and they reflect research that we did that we were not able to apply.

BATTERY CHARGING

Since future groups will be spending a lot more time doing pool tests it is recommended that future groups find an effective battery charging solution as soon a possible. Currently charging the AUV's batteries involves using a 24V 400ma manual charger. This involves charging the batteries in series and constantly monitoring their status. We believe that an automatic charger would save future groups time and frustration. Additionally this solution should be found as quickly as possible since all lead acid batteries should be charged and discharged at least once per nine month period to avoid loosing battery capacity.

PC-104 DISK STORAGE

Future groups will need to expand on the PC-104's storage capacity. During our research this year we have discovered an option that we think would be ideal for this task. Specifically we think that the solid state flash drive made by diamond systems with the part number FD-512-XT would be a good fit for the AUV. It has a 512mb storage capacity and it requires only a 5v source to run. Additionally if more storage is required people have had good success using laptop hard drives with PC-104s.

LABVIEW

Our group believes that in order for a group of mechanical engineers to be competitive in the AUV competition some advantage will be needed in the area of control system programming. We think that this advantage could come from the use of a program called LabVIEW. LabVIEW simplifies control system programming by avoiding the need to write machine interface code. LabVIEW also simplifies serial port programming and data acquisition. Our group believes that the successful use of LabVIEW will be pivotal to the success of the AUV project.

PRESSURE SENSOR

Our group has already purchased a pressure transducer for use on the AUV. The pressure transducer that we chose is the PX40-15G5V pressure transducer from omega engineering. We chose this transducer for its low cost, appropriate pressure range, and good media compatibility. Also this pressure transducer has an output that varies from zero to five volts. This is superior to mV volt output transducers because it eliminates the need for bulky and expensive signal conditioners.