

# **Advanced Snowmobile Track Design**

Final Report  
May 11, 2007

Benjamin Baldus  
Benjamin Cilley  
Kyle Fitzgerald  
Nicholas Zinck

## Table of Contents

I.	Project Introduction .....	2
	Motivation .....	2
	Literature Review .....	3
II.	Design Approach .....	7
	Preliminary Ideas .....	7
	Preferred Result .....	10
	- Embedded Chain Drive System .....	10
	-Composite Linked Sections .....	11
III.	Design .....	12
	Existing Design Dimensions .....	12
	Link Widths .....	13
	Connecting Pins .....	14
	Bushing/Bearing Selection .....	14
	-Bearing Material Selection .....	15
	Composite Selection and Fiber Orientation .....	15
	Final Prototype Model and Specification .....	17
	Theoretical Weight Comparison .....	18
V.	Fabrication .....	19
	Mold Construction .....	19
	-Process Analysis .....	19
	Bearing Fabrication .....	22
	Composite Lay-Up Process .....	23
	-Process Detail/Fabrication Trials .....	23
	-Problems/Areas for Improvement .....	24
VI.	Testing .....	28
	Bearing Failure/Tear-out Failure .....	28
	Impact Testing .....	31
	Slider/Track Interface Material Selection Tests .....	34
VII.	Appendices .....	37
	Appendix A: Annotated Bibliography .....	37
	Appendix B: Calculation Pages .....	41
	- Efficiency Analysis .....	41
	- Bearing Failure Analysis .....	42
	-Strain Energy Analysis .....	44
	- Composite Failure Analysis .....	46
	Appendix C: Testing Data .....	49

# **I. Project Introduction**

## **Motivation**

The Advanced Track Design project is a part of the University of Maine's involvement in the SAE Clean Snowmobile Challenge. The competition presents students with the task of modifying a current snowmobile design to improve the vehicle's performance in many areas of operation and function. The current performance snowmobile designs have a number of inherent flaws and areas in need of drastic improvement. One area that has seen little or no innovation in past decades has been the snowmobile track. The snowmobile track used on almost all makes and types of snowmobile today is an unequivocal source of loss in the overall snowmobile performance. On a snowmobile such as the Yamaha Phazer, with an engine with a power rating of 80 HP and forward motion efficiency of approximately 50 %, it can be estimated that at least 25% of power is lost due to the drive-train which leaves another 25 % of losses in the the track and suspension. Such a reduction in engine efficiency has a negative impact on snowmobile performance, especially in areas that are integral to success in the competition.

The SAE Clean Snowmobile Challenge, started in 2002, is open to engineering students in the last few years of their undergraduate education. The aim of the competition is to reengineer a commercially available snowmobile to reduce emissions and noise while also improving the snowmobile's overall performance. The competition is split into zero emissions and internal combustion engines categories, the latter being the area that the University of Maine takes part in. Within this category the teams are judged in the areas of engineering design report, manufacturer's suggested retail price, emissions, oral presentation, fuel economy, weight, acceleration, objective handling, subjective handling, cold start, rider comfort, static display, objective noise, subjective noise, and tech inspection. The behavior of the track and suspension system is central to the performance of the team snowmobile in many of these categories. The goal of the advanced track design team is to eliminate the flaws in the current track and create a new design that will improve performance in areas such as weight and fuel economy among

others. Currently, the 2007 competition rules state that only commercially available tracks are to be used during the competition. This being said, another goal of the 2006-2007 advanced track design team is to formulate an appeal to SAE for a rule change that would allow for the use of student designed tracks. In general, the central objective of the team is to lay an infrastructure that includes a final design, small scale fabrication, and a series of tests so that the design may be actually implemented by the University of Maine Clean Snowmobile team in future competitions.

## **Literature Review**

The following pages very briefly summarize some our research on the design and construction of vehicle tracks. Included in the review are key aspects pertaining to the competition and to track design in general.

### **Brief History of Track Use**

Track-type vehicles and automotives can be dated back to sometime in the 1850's. Farmers and other agricultural workers determined that the use of a track would be more suitable for the more rough and unstable terrain that they were faced with on a day to day basis. A vehicle track enabled them to traverse more terrain though usually at the cost of speed. The early 1900's brought about the use of tracks in conjunction with heavy machinery and inevitably military applications. Over the years the track-type vehicle technology has seen new innovations and better designs. More recently the addition of fiber or composite reinforcements placed in rubber tracks has allowed for more versatile and effective track systems.

### **Track Performance/Efficiency**

Tracked vehicles are in most applications used to travel along diverse terrain where vehicles with tires are often inefficient. Consequently, the use of a track in traveling over winter terrain is a perfect fit. The key to effectively navigating such varied off-road

conditions lies in optimizing the traction and flotation of the vehicle in accordance with the track-terrain interaction. Consideration of the terrain properties is central to the design of a vehicle track system and the track's ability to compact the terrain in question is very essential to effective flotation and traction. For snow and ice covered terrain, variables such as temperature, depth and grain size all ultimately have an effect on the snow pack density and ultimately on the track efficiency and suitable design.

Flotation above a given terrain surface is where the vehicle track design came into play as it distributes the load on the ground across a larger contact area. By distributing this load concentration, a track is able to create stability where four or more tires with a small contact area would just sink into unstable terrain. The traction of a track is also essential to the mobility of the vehicle over a specific terrain. A tracked vehicle's traction is dependant upon a multitude of variables and is directly related to the speed and power of the vehicle. Among these many variables, there is a group that is important in the case of the snowmobile track:

#### Important Variables Affecting Flotation and Traction

1. Grouser/Lug/Stud Shape, spacing(g), Height(h), connection type, and geometry.
2. Contact Length (L)
3. Slip Rate Value
4. Angle of Attack ( $\alpha$ )
5. Driving Sprocket Position
6. Draw Bar Pull Position
7. Vertical Load (W) and eccentricity (e)
8. Number and Spacing of Road Wheels or Bogeys
9. Rigidity of the Belt/Track
10. Road Wheel/Bogey Stiffness
11. Suspension Stiffness
12. Track Tension
13. Track Weight

Note: Letter Designations for Figure 1 below.

These variables in combination with the track-terrain interaction all have an effect on the dynamic motion and operation of the track and should be taken into consideration when designing a track system.

Ideally, the track design with the best power output would be a rigid, high tension track that created a small amount of friction and slip. A general form of the energy balance in a track can be written as follows

$$\text{Input Energy} = \text{Output Energy} + \text{Work Energy} + \text{Interfacial Energy}$$

In the case the Work Energy encompasses work done by friction and the work expended displacing and compacting the ground, while the interfacial energy is energy lost at the slip surface. The work and interfacial energy are dependent upon many variables pertaining to the vehicle traction and terrain already mentioned. In improving an existing track system, an investigation of the sources of miscellaneous spent work should be performed. Reducing or eliminating these sources along with optimizing the traction and flotation of the vehicle should be the main objectives in increasing the track efficiency.

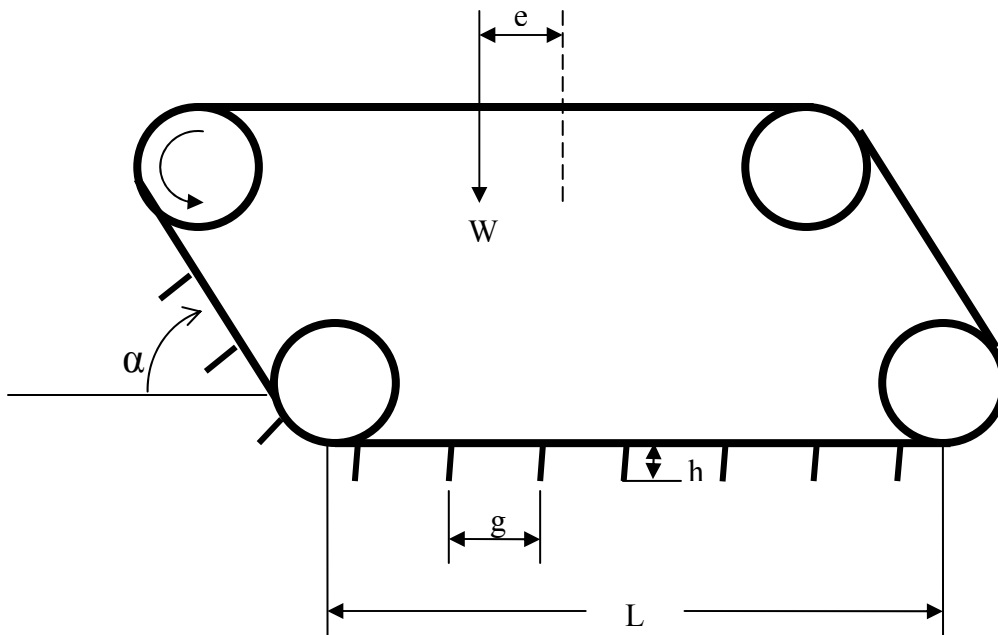

**Figure 1** Basic Track Schematic

## **Lugs and Studs**

The track lugs are the rubber protuberances whose design and placement have a large impact on the performance of the track. Lug design varies with the specific application of a given track. Tracks used in racing usually have shorter lugs than every day riding tracks. The racing tracks range from no lugs to profile heights of 1.5” while cross-country tracks range from 1” to 2.125”. The profile heights of the tracks are important in controlling the degree of vehicle traction while the positioning of the lugs helps to determine the noise that the vehicle track makes.

The central idea behind noise reduction is controlling the air flow near to track. The lugs are placed so as to constantly redirect the air flow which in turn decreases the air speed directly over the lugs and the noise to wind vibrations. The redirection of the air flow is achieved in part by incorporating wide gaps in the lug pattern that spans the entire width of the track. In the case of many snowmobile tracks, the breaks in the lug patterns are repeated every third row.

Studs are often added to the track lugs to add traction to the sled, especially in icy areas. Similar to lag bolts and usually drilled into the lugs, studs are normally an aftermarket modification. The decrease in slipping provided by the addition of studs helps to increase acceleration as well as increase the control that the driver has over the snowmobile.

With the addition of studs and of increased grip on icy surfaces comes resulting increase in weight and subsequent decrease in engine efficiency. The typical weight increase is very small compared to the weight of the entire sled, approximately 5 lbs on average. The addition of studs, though useful in the short term, may have a negative effect on the track’s operational lifetime.

## **Slider Material Selection and Coefficient of Friction**

Most snow mobiles currently incorporate sliders made from a material called Ultra High Molecular Weight or UHMW extruded polymer plastic. This has been tested to have the highest abrasion resistance of any thermoplastic while also boasting outstanding impact strength even at very low temperatures. While it is a thermoplastic it self lubricates rather than caking and sticking. The UHMW also has great sound dampening properties. With the coefficient of friction between the UHMW and stainless steel being around 0.15 this is far less than that of steel on steel or even steel on nylon. The material selection for the slider should be based on most of the factors that the UHMW has already proven to perform well under. Those factors being: impact strength, abrasion resistance, low temperature stress, and coefficient of friction. Compression molding rather than machining the UHMW has proven to be the more effective method. The compression molding wastes less material and is also proven to wear slower than the machining method of shaping the thermoplastic. UHMW is considered the all around best choice for the sliders, bogey wheels, and possibly the drive sprocket because of its favorable material properties.

## **II. Design Approach**

### **Preliminary Ideas**

Key to establishing the team's approach to the new track design was to study of tracked vehicles and their mechanical behavior. To determine what track types and designs would benefit this application, the research of previous designs and methods were taken into great consideration. In recent years the application of performance sports has taken the design of many track systems to a new level. The current designs of tracks for snow going vehicles are focused primarily on the longevity of design. Subsequently, attention to the track's effect on snowmobile performance and efficiency suffers and is not the principal concern.

The underlying motivation and basis for the design approach was to eliminate some of the energy losses inherent in the current track system in order to increase performance throughout the Clean Snowmobile Competition (CSC). In designing a track to perform under certain conditions, the consideration of the terrain, the loads on the track and overall efficiency are all important factors affecting the design. In weighing the importance of such factors in the design, some were determined to be more important than others. The traction and track-terrain interaction in general was determined to create relatively small and unavoidable losses in existing track designs. With this in mind, it was decided that there was little room for improvement in this facet of the design and that alteration to the lugs and overall surface area of the track would not be a focus for the team. The areas of the track design that the focus was to be on was the frictional losses, the bending losses, the weight, and the drive system efficiency.

#### *Reduction of Frictional Losses*

The current track design used in most all snowmobile applications has many inherent losses due to friction. The friction created at the track-slider interface is one of largest apparent frictional losses in the track drive system. While UHMW has been established as one of the best choices for slider material, the team decided to look at possible alternative materials for the slider and for track-slider interface surface on the track itself. Another idea proposed for reducing the friction was to implement more bogey guide wheels or possibly even a series of wheels where the slider now exists on the suspension setup.

#### *Weight Reduction*

The most current track material consists of butyl rubber reinforced with fiberglass rods at the drive sprocket-track interface. The specific track in use on the University of Maine's Arctic Cat 660 weighs approximately 45 lbs. While a heavier track provides for a greater inertia and subsequently better coasting ability, it requires more power to drive and thusly reduces the efficiency of the engine drive. A lighter track construction would increase

the effectiveness of the engine and subsequently increase the fuel efficiency, a judged quality during the clean snowmobile competition. As weight is also an area that the snowmobile is judged on during the competition, a reduction in weight would have a positive impact on several areas of the performance during the competition.

### *Reduction in Bending Losses*

One of the largest energy losses identified in the track was the loss due to the bending of the rubber throughout the drive process. For each cycle of rotation for the track, every inch of the rubbers length is bent around each of the four rounded contours of the suspension system. The energy required to bend the track per cycle of the rotation undoubtedly amounts to a huge loss. To reduce this loss, it was decided that the track should be stiffened up to reduce the amount of energy and efficiency dissipated in bending. One proposed idea to counter the bending loss problem was to implement light weight, high strength fiber reinforced composites to construct the track from rigid links. Use of composites would effectively solve the problem of bending losses while also providing a comparable or even improved weight specification.

### *Increase Efficiency in Drive System*

Efficiencies of belt drive systems were found to be much lower than that of a more stiff and solid drive system (i.e. chain drive) for the very same reasons described above in the section concerning bending losses. Research shows that chain-sprocket driving systems can achieve efficiencies upwards of 80 to 95% and sustain operational lives considerably longer than comparable belt driven systems. In addition to a much smaller window for design life and comparably lower efficiency than chain drive systems, a continuous belt cannot easily be repaired in the event of an unforeseen tear. Though neither system is easily repaired, a broken link in chain is much easier to replace than an entire track, which would undoubtedly be the case with a catastrophic tear.

## Preferred Result

The team formulated a number of ideas, each with their own impact on the design approach. Figure 2 shows the House of Quality analysis for several of the team's ideas. After examining the advantages and disadvantages of each idea, the group decided to focus on two major design ideas for consideration: an imbedded chain drive system and linked composite section track.

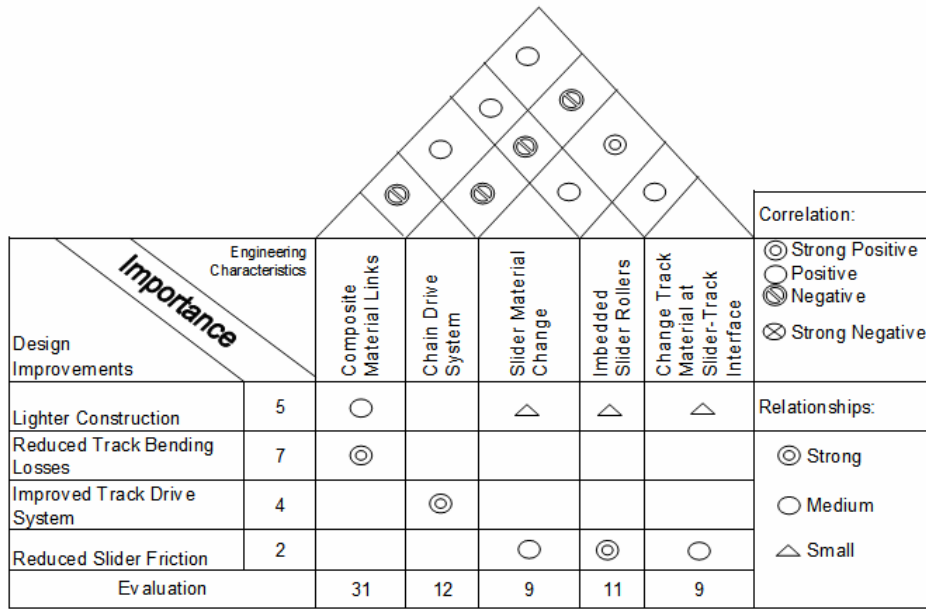

**Figure 2** House of Quality Design Analysis

## Imbedded Chain Drive System

The idea of a chain drive system was at first a very plausible and seemingly effective solution to the problem of reduced efficiency in the track. The team devised plans on how a chain could be implemented into a track drive system. One of the central ideas was imbedding the chain in a rubber track similar to the existing one. After consideration, the imbedded chain system was found to have many more downfalls than advantages and to be improbable and ineffective for this particular application. Imbedding a chain in rubber would not solve the problem of bending losses as the rubber would still need to be bent around the same contours to an equal or only slightly lesser degree. Additionally, small chain links such as those on a motorcycle drive chain would

be susceptible to debris collection and would be very hard to replace if they were damaged on trail. One of the largest downfalls of a chain system is the dramatic increase in weight that it would cause. The team's research of chain design yielded an estimated weight for a single chain able to operate under the running conditions of the snowmobile to be approximately 20 lbs. The current track only weighs approximately 43 pounds so the addition of a design that would implement two chains would be almost just as heavy the existing design in just chains alone. This fact by itself makes the implementation of a chain an extremely undesirable idea for development

### **Fiber Reinforced Composite Track Links**

With the imbedded chain design eliminated as a probable solution, the group decided that we would focus our efforts on the development of a composite section design. As the use of long sections of such a material is out of the question for such an application, the team decided on series of short track links because of their mechanical similarities to a chain drive system. Allowing for the incorporation of pin connections, a composite linked track would affect significantly smaller bending losses similar to links in a chain drive. The reduced bending coupled with the great potential for weight reduction made this concept the team's best choice for examination and development.

The preliminary design for the project was to incorporate a rubber core encased by a composite shell. The rubber core was deemed necessary in anchoring a row of tractive lugs of the same material. With a preliminary design in mind, the team set out to optimize the dimensions and properties of a new composite link prototype design.

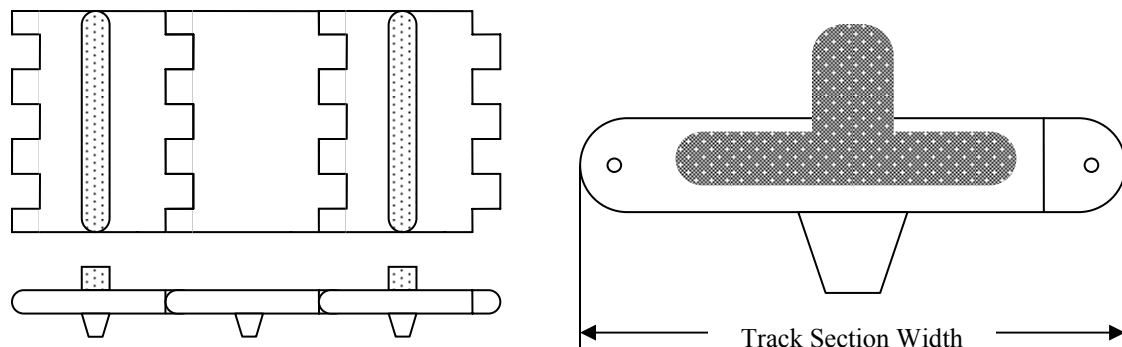

**Figure 3** Preliminary Composite Link Design and Link Cross-Section (right)

### III. Design

#### Existing Design Dimensions

The first step in designing our track link sections was to identify the current dimensions and properties on the existing track and deciding which of these dimensions should be translated into our new design. Pictured in figures 3 and 4 are pictures of a track section for old noisy track for the Arctic Cat competition snowmobile and a solid model of the new track used on the Arctic Cat. Due to the availability of the Arctic Cat's track for examination and measurement, it was this track that the team decided to emulate in our new design. The track currently in use on the competition snowmobile is constructed of molded, reinforced rubber. The weight of track is 43 lbs, the length 144 inches, the width 15 inches, and the height from outer lug to inner drive train lug is about 1.85 inches.



**Figure 4**  
Old Arctic Cat  
Snowmobile Track  
with metal track-  
slider interface clip  
removed.

As described before, the existing designs for the tractive lugs and for the track surface area have little room significant improvement, so the dimensions for the track width and length along with the lug patterns were to be incorporated into the new design. Likewise, the drive lugs on the bottom need to remain the same in order to use the same or similar drive sprocket, so that part of the design was to also be translated into the new design.

**Figure 5**  
Solid Model of  
Current Arctic Cat  
Snowmobile Track.

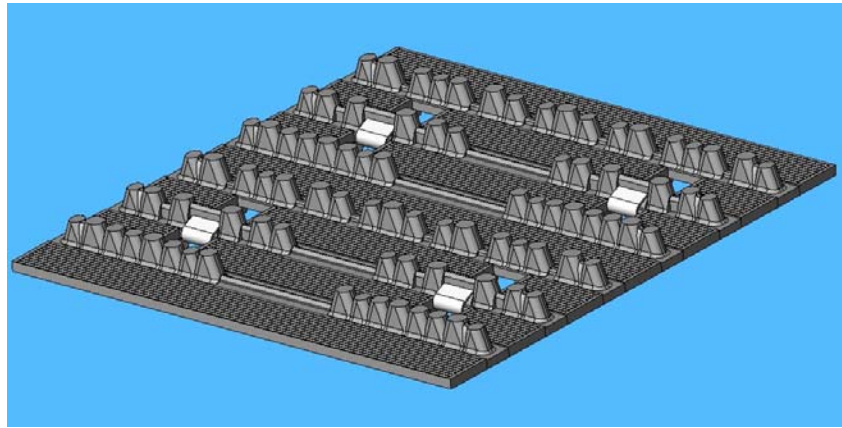

Holding these dimensions constant in our design, the link width along with specification of fiber orientation, layer thickness, pin and bearing selection, and weight comparison were the remaining qualities to be determined for our design.

### **Link Widths**

The current track has a distance between the rows of tractive lug patterns of 2.5 inches center to center. The top tractive lugs on the current track are approximately 0.962 inches wide at their base while the bottom drive lugs are 1.015 inches wide at their base. The base widths for the lugs were originally designed with respect to the shear force applied to the track and the resulting stresses that the lugs need to withstand. As previously established, these values will not change in our new design so were the primary design constraints for the width of the track.

The main design criterion that the group considered was the use of the smallest width possible to minimize the bending moment. In choosing the section width (Figure 3), the feasibility and ease of fabrication, the space for the interlocking connection teeth, and the width of the anchoring rubber to be encased in the composite also had to be taken into account. With the fixed lug base widths and a reasonable distance for the hinging connection teeth of about 0.5 inches, the team decided on a total section width of about 2.5 inches. This would result in 2 inches from pin center to pin center, and would allow for 1-1.4 inches of width for the rubber anchor depending on the amount of composite material used. This width also more than accommodates the base widths of the tractive and driving lugs on the top and bottom of the track.

## Connecting Pins

In such a loading case for a connection pin, the failure mode analysis should be done on the shear failure of the pin. The basic formula for shear failure is  $\tau = P/A$ , where  $\tau$  is the shear stress and  $P$  is the load applied to the connecting pins, and  $A$  is the area of the applied force. Since the pin is in double shear this area would be half the area of the connecting pin for each direction, and the shearing load is equal to the track tension,  $T$ . The equation for the allowable stress on the pin thusly becomes:

$$\tau_{\text{Allowable}} = (2P)/(\pi d^2)$$

According to this calculation the yield strength for a pin of diameter 0.125", with a safety factor of two and track tension of 471 lbs is 38.4 kpsi. With this allowable shear strength, an appropriate pin material was determined to be basic steel or possibly a higher strength aluminum alloy.

The above calculation was done for a scenario where there is only two interlocking teeth acting on the pin. In the new design, there will be four teeth interlock three, which in turn will distribute the load even more. Consequently the safety of factor will go up and the chance of pin failure will be not an issue.

## Bearing Selection

Due to the unique design of the composite linked sections, the links are to be held together by an 1/8<sup>th</sup> inch rod. This introduced a new issue, friction at connection points. To keep friction to a minimum the composite could not come into contact with the rod at any stressed contact points (faces of each side "rail"). To aide in keeping the friction of the pins low a bearing would need to be used. In order to keep weight down an alternative to a typical roller bearing was desired. With roller bearings usually constructed of steel race and ball, it was determined that the added weight was not desired. When considering other types of bearings a flanged sleeve bearing was determined to provide the best

resistance to friction on two surfaces: the contact point between composite links and between the connection rod and link.

## **Bearing Material Selection**

When considering bearing material a few materials were considered: UHMW – due to its low coefficient and ease of manufacturing, Teflon – due to its extremely low coefficient of friction and performance in such a broad temperature range. Teflon was chosen due to its extreme operating temperatures -300 degrees to 500 degrees F. Whereas UHMW had an operating temperature between -200 and 180 degrees F. Both temperature ranges were acceptable for this application but the Teflon proved to provide a lower coefficient of friction and was ultimately selected for use in this design. Once Teflon was selected the calculations were made to determine the bearings dimensions. The design was constrained by the size of the rod and the thickness of the track. These two restrictions left little room for design. The Teflon was found to have an acceptable strength for the requirements and was selected as our bearing material. See bearing failure analysis in Appendices.

## **Composite Selection and Fiber Orientation**

The use of composite material in constructing track sections is advantageous due to its lightweight and high strength. There are a number of fiber reinforcements available including fiber glass, Kevlar, and carbon fiber. In order to eliminate the bending losses in the track, an extremely strong reinforcement is necessary for the composite construction. With this in mind, the team decided to reinforce our composite for the track sections with carbon fiber. As the strongest, readily available reinforcement, it was decided that it would be the best choice for our application. Carbon fiber's high strength allows for less material to be used, in turn reducing the overall weight of the track. As for the composite matrix, the cured resin resulting from the selected hardener and epoxy simply needs to be within an acceptable operating temperature somewhere between -50 °F to 200 °F.

In selecting the configuration of the reinforcement to be used for this application, it is important to identify the needs of the design. There are two major design areas that were the focus in fiber orientation and thickness. The first was making the composite able to withstand the tension in the track and to not result in a tear-out situation. The second was to make the track stiff enough to resist bending but not so rigid that it would not have any give whatsoever. To solve the second problem, the design would have to incorporate a fiber orientation that is favorable for bending in the direction indicated in Figure 6. In order to achieve this, the team decided that the orientation the fibers should be staggered between 45 and -45 degrees from layer to layer. By using 45 degree angles, the strength of the piece will not be concentrated in the direction of the tracks motion. The strength in the direction perpendicular to the fibers will remain the same while the strength lateral to the track width will be slightly reduced.

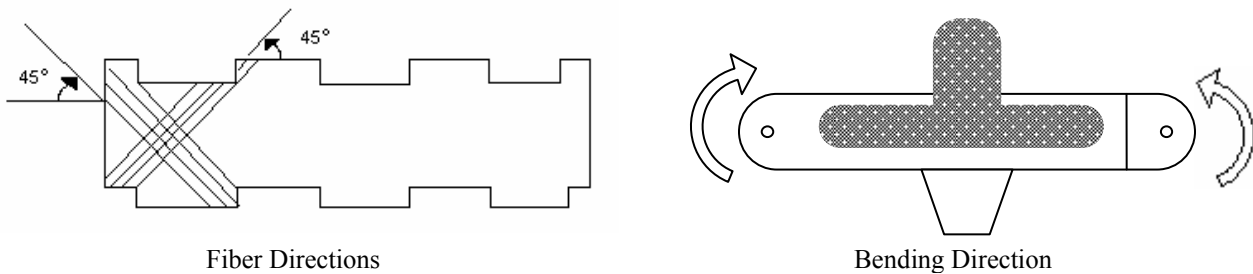

**Figure 6** Simple Fiber Orientation Diagram and Bending Direction

Having established a fiber direction, the next area focus was selecting the number of layers that should be used in order to avoid tensile and tear-out failure of the piece. The failure of the piece due to the tension in the track will occur along the vertical plane at the pin connection point as pictured in Figure 7.

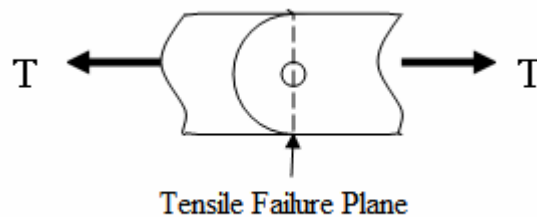
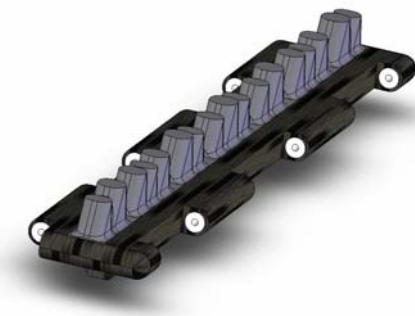

**Figure 7** Tensile Loading Case

The composite analysis of the track is dependent upon the following engineering characteristics: modulus of elasticity,  $E$ , for the principle directions; the tensile and compressive strengths,  $\sigma_t$  and  $\sigma_c$  for each principle direction; the number of layers,  $N$ ; and their each layers angular orientation,  $\theta$ . With these quantities fixed, the first step to calculating failure in the piece would be to calculate the reduced stiffness and reduced stiffness matrices for each layer. These matrices are functions of the moduli of elasticity, poisson's ratio and the layer angle. With these matrices and the loading case, the engineering stresses and strains can be found and used to calculate the Tsai-Wu Failure Criterion for the composite. The team wrote a computer program in the Fortran language to calculate the strains and stresses in each of the layers and the Tsai-Wu failure mode of the composite in tension (the details of the computer program and composite analysis are located in Appendix B. After input of our design specifications, it was determined that the three layers with alternating 45 degree orientations would be adequate in the given application.

## Final Prototype Design and Specifications

After examining each of the major design criteria, the group went to work on creating a model of the new design. Using the established characteristics and dimensions, the team came up with a design that both met the specifications of our design criteria and also could be realistically manufactured with the resources at the team's disposal (save the intricate lug pattern). A solid model of a prototype track piece is pictured in Figure 8.



**Figure 8**  
Solid Model of Prototype Track Link Section

The pins selected for the design are 1/8 inch stainless steel stock rod which can be cut to the appropriate length. The team decided on the stainless steel rods because of their high shear strength, their widespread availability, and relatively low cost compared to lighter weight, high strength aluminum alloy rods.

After analysis of the fiber orientation, it was determined that the entire piece would implement three layers with alternating  $\pm 45^\circ$  directions through the direction of the tensile force. Also included will be two layers of unidirectional fibers at  $0^\circ$  and  $90^\circ$  in the drive lugs and interlocking connecting teeth in combination with filler bubbles and chopped fiber-resin paste to fill in the contours and void areas.

The team established that the openings on the track designed to clear debris would be included separately from this particular prototype piece. The team decided its focus would be on exploring the feasibility of this design before adding in sections that incorporate an opening for debris disposal.

## **Theoretical Weight Comparison**

With a solid model of the track complete, a weight comparison can be made between the theoretical and actual tracks. Using the Solidworks mass properties function and the appropriate densities for the bearings, composite, and rubber, the theoretical weight of one track section minus the pins was determined to be about 1 pound. This calculation was made assuming the entire volume of the composite section in the model is considered to be composite. If hollow filler bubbles are used in place of a resin-chopped fiber paste, we estimate that the volume of the composite could be reduced as much as 50%. In addition to reducing the composite volume, advanced techniques in either water jet cutting or injection molding of the rubber anchor/lug pattern would allow for a precise bare minimum volume of rubber needed for a single track piece. Consequently, a piece with the reduced volume of rubber and of composite would result in a weight of about 6/10 lbs per track piece. These optimized pieces combined with the steel connection pins would result in a total track weight of approximately 47 lbs. This would result in only a

slight increase in the weight of the track currently in use on the competition snowmobile, though the team believes that such an increase in weight, which could in other cases be due to differences in driver weights, is a small price to pay for the increase rigidity that the design creates.

## **IV. Fabrication**

### **Mold Construction**

The primary step of the mold construction was material selection. Many materials used in composite construction will adhere to the epoxy resin used. Initially mock up parts were made using a wood mold and as a release a urethane tape applied over all contact surfaces. The wood and urethane setup proved to be time consuming and ultimately ineffective. Doing some research and speaking with others who had done some extensive work with composites we found that ultra high molecular weight (UHMW) plastics give a non-porous surface allowing the part to break cleanly free from the mold once the epoxy resin had hardened. Simple part mock-ups proved that the part released very easily from the UHMW and was ultimately chosen for the mold material.

### **Process Analysis**

The process to create such an intricate composite part was the main focus of the group. With such small areas and very complicated parts to be built, the overall construction process was extremely difficult. To ease in the construction of a complete part many different approaches were considered.

- Pultrusion – Making one solid piece of uniform material in order to unify strength and size specifications.

- One Piece Construction – lay up part as one continuous part with all aspects incorporated during single construction.
- Multi-piece Construction- create parts as separate molds and construct them together as a final piece.

Pultrusion was quickly shot down as a result of orientation of fibers. To attain the desired strength of the part the fiber orientation would have to be in the direction of the forces applied to the piece. Pultrusion methods are mainly used to create parts and objects that need to maintain strength in a lengthwise orientation. The design decided upon would require the fiber to be at 90 degrees to this process, therefore not meeting the needs of the design.

One piece construction was the next option. To create the strongest and most uniform pieces creating the part as a single construction would allow for the strongest and best configuration of fibers. With a one piece construction laying up the part would be extremely difficult. The link sections were designed to be ½ inch thick with the angles and tight corners of the part it was found to be very difficult to get the correct orientation of fibers and vacuum bag pressure on the finished part. With these constraints a single mock-up part was deemed too difficult to do with limited resources.

The multi-piece construction was the only practical solution to such a complex part. Through analysis of what parts will carry the most load and stress it was determined that making the part in three sections and then combining them to construct a final part was the most optimal way of creating such an intricate design. Doing each part separately the vacuum bag process could be most effective to keep the resin content down. With this design process as the main focus, concentration was then put into the creation of the molds. Working with wood as test specimens to assure that the correct shapes could be produced with the tools provided, UHMW was then used to create the final mold pieces.

The mold consisted of two side “rails” used as the connection points. Each mold being the exact negative of the other allowed for the joints between the pieces to line up and provide a solid connection point between the links.



**Figure 9** - Side mold and test piece constructed from mold



**Figure 10 (a)** – Manufactured Base

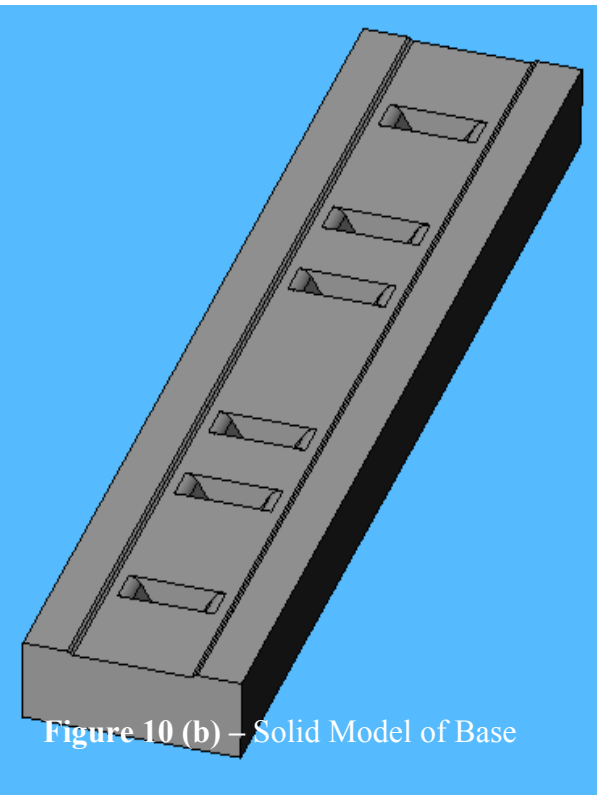

**Figure 10 (b)** – Solid Model of Base

The base mold consisted of the drive lug pattern and a  $1/32^{\text{nd}}$  in rise on each side of the lugs allowing for a lip to be used in the final lay-up of the parts. The mold pieces creating the lip were to be removed to allow for a complete mold for the final lay-up.

To complete the molding process a final configuration of all mold parts was created to allow for final lay-up.

## **Bearing Fabrication**

Along with bearing material selection mentioned above the sizing of the bearing was constrained due to the sizing of the composite links. With a known sizing, selection of a bearing was then the next issue.



**Figure 11 - Flanged Sleeve Bearing**

Researching local dealers and providers it was determined that purchasing a bearing of such size of any material would not be cost effective, resulting in in-house fabrication of each individual bearing. With the decision to make the bearings in house, it was then an issue to determine the ideal material for such an application. Once the material was chosen the sizing of the bearing was to be determined. Knowing the overall thickness of the link, determining the sizing of the flange of the bearing was not difficult. As much area of the contact surface that could be covered without disrupting the composite fiber lay-up was the optimum design size for the flange. The calculated optimal size was deemed to be  $3/8^{\text{th}}$ 's of an inch. The sizing of the shaft was determined to keep an  $1/8^{\text{th}}$

inch of Teflon around the 1/8<sup>th</sup> inch rod at all times. Therefore 1/4" inch was determined. The bearings were made to these specifications with a 1/8<sup>th</sup> inch hole through the center to allow for the rod to be firmly held but allow for rotation. Using Teflon stock and lathe the bearings were created to spec.

## **Composite Lay-up Process**

### **Process Detail / Fabrication Trials**

The process of fabrication was the most difficult aspect of the build phase. To assure the strength desired from the design, the fabrication had to be done as to assure fiber orientation and proper thickness at all specified points. Tight corners and sharp edges made conforming fibers to the mold very difficult. The fibers had to remain uniform in their orientation to each other as well as in the direction of the stress being applied to the part. For the side molds the fibers had to remain perpendicular to the long axis. Assuring that the fibers would hold the tension force applied to them during loading. To do this the fibers were forced into the curves and then placement of the Teflon bearings was done. To hold the bearings in place for curing the 1/8<sup>th</sup> inch rod was inserted into the mold. To assure that the concaved areas held their structure a fill of chopped fiber was used. Once the concaved areas of the rails were filled the flat raised sections were laid in and final composite fibers were put lengthwise on the piece. (Pictured in Figure 9)

The base mold followed much the same process. The lay-up included fibers in the lateral direction of the drive lugs to allow for strength in these areas. Once the lateral fibers were laid in, a longitudinal strip was laid up to assure a connection between all fibers and final overlays of carbon fiber weave to add strength. A fill similar to the side rails was used to attain structural integrity in the drive lugs.

Once all carbon fiber was laid into the molds a vacuum bagging process was then used. Vacuum bag packing was a major help in keeping weight down and part strength. With added resin in the fibers the part would become more brittle and prone to fracture. The vacuum bagging process allowed for use of less resin and provided the same result. To assure that too much resin was not saturated into the carbon fiber a process known as

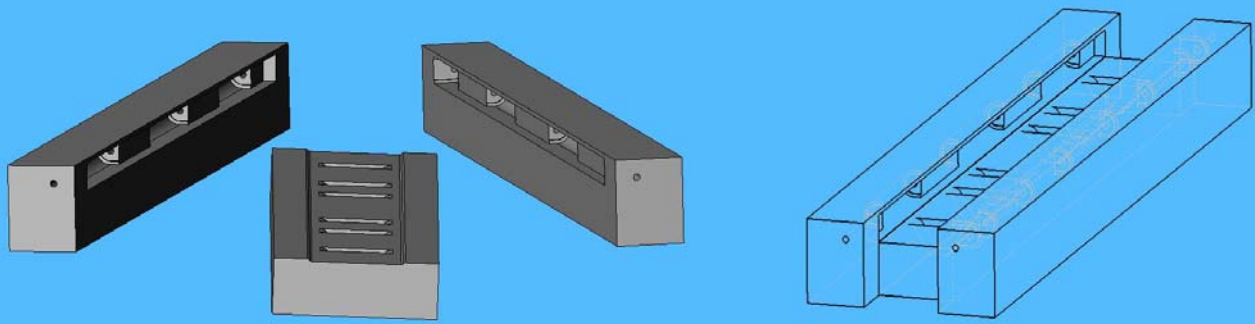

Figure 12 Solid Model of Track Section Composite Mold

stippling was used. By cutting down the brushes of a 1 ½ inch paint brush to create stiffness in the bristles, using that to work small amounts of resin into the carbon fiber. Ultimately much less resin was used, which resulted in a noticeable reduction in weight. Once each part had cured (2 sides and base), the process of constructing the desired final part began. To assure proper alignment of all parts, the molds were aligned and connected to provide for one complete piece.

Due to budgetary constraints the rubber used for the tractive lugs was a simple cut from rubber stock. The ideal piece used would be cut via water jet or injection molding to allow for filling of all necessary curves. With a cut or molding like water jet or injection, unnecessary rubber can be removed from the design and ultimately reduce the overall weight. Inserting the rubber and putting a final wrap of carbon fiber weave oriented at 45 degrees around the rubber connecting the three pieces created the final part. With the part completed it was determined that a uni-tape wrap around the entire part would provide the necessary strength to withstand the tensile load.

## VI. Problems/Areas for Improvement

In the fabrication of the part many improvements and problem areas arose. The first noticeable problem was with the mold fabrication. With the equipment provided it was very difficult to keep tolerances and orientation in perfect alignment. With the mold design of multiple short sections each had to be drilled for the 1/8<sup>th</sup> inch rod. Keeping

alignment of each section was very difficult and resulted in a less than perfectly straight hole to hold the rod. With this miss alignment the forces would not be applied in the direction desired from the design. With limited supplies, time and budget recreating the entire mold would have been very difficult. The results were not what was desired but accurate enough to continue with testing and fabrication of trial parts. With a limited on-hand supply and widths of UHMW to build mold sections from, the final part lay-up had to be fabricated from wood and other materials to help with structural alignment. With more material at hand a complete UHMW mold would have been possible.

The fabrication process of the actual parts was the most difficult. With the severe angles, contours, and size of the parts lay-up was extremely difficult. To assure uniformity many precautions were taken, but ultimately with human error as the biggest fault, resulting in less than desired parts. Keeping proper alignment of the fibers in the mold proved to be very difficult before and during the vacuum bagging process. With this as an issue many early parts were discarded. For future trials a refined vacuum bagging system may be an advantage to the parts. Creating the parts in succession proved to also be an issue with the final construction. The lip made to allow connection of the base to the side rails was not as effective as desired. With the vacuum bagging process the edge designed to line up with the base mold was not uniform. With a non uniform edge the final connection was filled with gaps, reducing the structural integrity of the part. Therefore an alternate system must be adapted. Possible solutions would be to create the side rails and base as a continuous part, leaving the inlay of rubber and final layers of composite the only thing to be done once cured.

The insertion of rubber became another issue. Cutting each piece to the desired size was not possible with the fabrication tools provided to the team. The ideal situation would be to use a flow-jet cutting tool to attain the exact shape of the rubber inlay desired. Another method would be to create a mold of the desired rubber core and use an injection molding process to fill the mold and create the lug pattern. With these processes an ideal shape and size would be attained. With the desired sizing the weight would be greatly reduced compared to the process used in preliminary test samples.

The current design uses a flanged sleeve bearing to reduce friction at the connection points. The overall length of the bearing is  $\frac{1}{2}$  an inch. With the flange setup

the majority of the force once loaded was applied at the very outer edge of the flange. Due to the low weight of Teflon the possibility of introducing a solid sleeve bearing is a possibility. With a simple sleeve bearing fabrication time would be reduced as well as uniformity across the bearings. Also the force applied to the bearing flange would be dissipated more throughout the entire bearing as opposed to the flanged edge.

One aspect of the design discussed but never attempted was a way to incorporate windows for release of debris. One topic of discussion was introducing an aluminum sleeve implanted into the part. This ultimately adds weight to the design and could possibly reduce the strength of the composite link. The track used on the 2007 competition sled is considered a “closed window” track, where the openings between lugs alternates around the track. The 2008 snowmobile is equipped with an “open window” design where there is an opening between every lug continuously around the track.



**Figure 13(a)** – Closed Window

**Figure 13(b)** – Open Window

With the open window design there is much more opportunity for debris to be cleared from the track/slider interface. With the complications of placing a hole through a composite section and breaking the fiber loop around the part, alternate ideas may need to be explored. The track to slider interface was a large topic of discussion with the group. Much of the noise from the snowmobile and loss of efficiency is through the slider/track surfaces. The noise issue is very important for the competition. When first approaching the issue of increasing efficiency in the track a complete roller setup was explored. The idea was not carried through due to the focus of the team turning more to the composite track design. Ideas of imbedded roller bearings, implementation of added bogey wheels to the slider/suspension setup was considered but never fully explored. The concept

considered would be very similar to asphalt racing. Due to the design of the slider system snow is used as a lubricant. With asphalt racing there is no natural lubricant for the interface between track and suspension. Rules for asphalt state that no external lubrication system may be used.



**Figure 14** – Asphalt drag racing slider solution

Therefore a complete roller system is used. To keep the track away from contact points many bogey wheels are placed across the suspension and at the outer edges to allow the track to remain free from the friction forces encountered with a conventional slider setup.

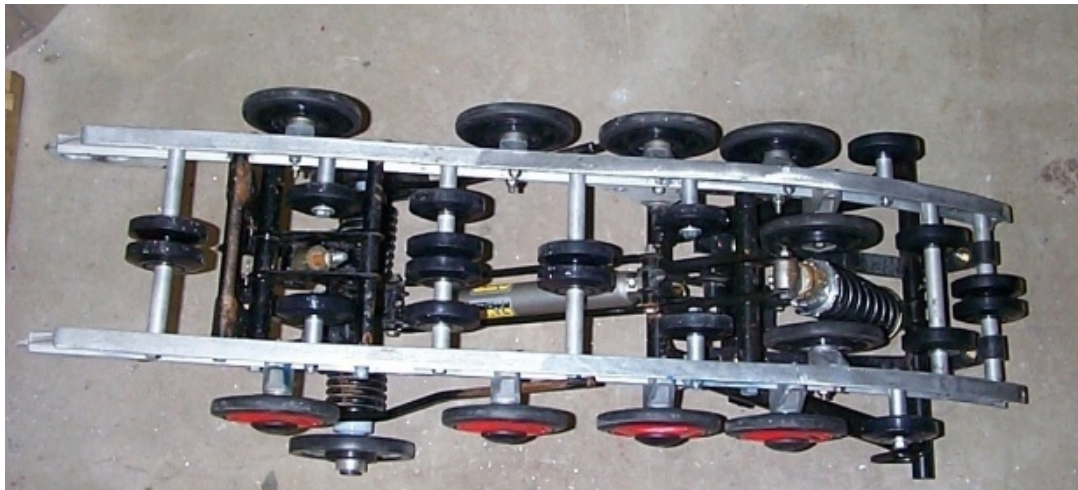

**Figure 15** – Bogey wheel configuration

With this setup the friction losses from the track and also noise would have an incredible decrease. With the addition of such an extensive bogey wheel system weight will be added but the overall gains may prove to outweigh this considerably.

## **V. Testing**

### **Bearing Failure/Tear-Out Failure**

#### **Theoretical**

We completed calculations for the bearing failure and tear-out failure to determine the loads that needed to be applied for the experimental data to be obtained as well as estimation of the final design criteria. All calculations assume uniform fiber orientation and uniform Teflon bearings. For the tear-out failure refer to the composite design section. For the bearing failure analysis refer to the appendices under bearing analysis.

#### **Experimental**

##### **Introduction**

The Advanced Track Technology design group needed to determine the load that could be applied to the linkage of the prototype. Proof testing was the process that was chosen by the group. This test is the best way to experimentally determine the load that would still allow the link to function under estimated running conditions. Our method of applying this test was to make an apparatus that would support our calculated applied load at a specific point in the link. The stainless steel connection rod was placed through one end of the link and the ends that needed supporting were placed into a setup as shown in figure 16. A load would be applied by using a weight hanger. In the setup of the track link prototype test piece we had to assure that the weight was applied at the proper points on the connection rod. The group was looking for failure of the Teflon bearings, the stainless steel rod, or the composite link section.

## Experimental Apparatus and Instrumentation

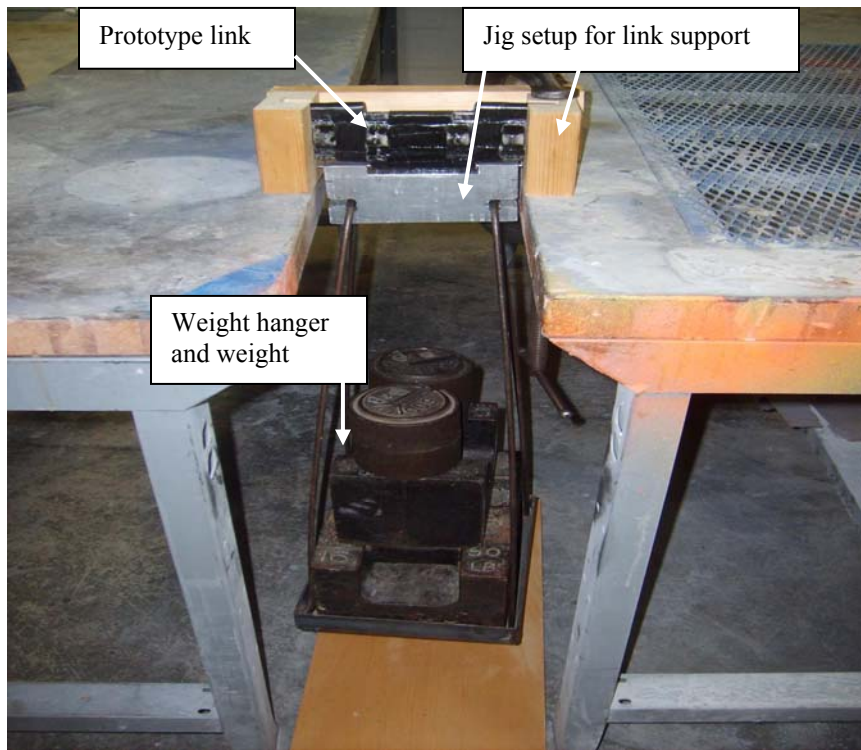

**Figure 16** Tear-out/Bearing Failure testing apparatus

### Procedure

The process of loading the prototype link to a specific point was done by placing the setup between two supports. These supports allowed enough space for the weight to be hung from the apparatus. A distance of seven inches between vertical supports was used based on our calculations. We used the three inch link section to determine our applied load needed for a factor of safety of one, although we were looking to satisfy a factor of safety of two. Completing the test with a weight of 149 pounds would adequately suffice for a factor of safety of one. The Initial load applied was 50 pounds. We then increased the load at an increment of ten pounds per trial. We were looking to prove that the prototype would withstand a factor of safety of two.

### Results and Conclusion

Upon completion of the proof testing the total applied weight was 397 pounds. Working with a factor of safety well over two, this easily satisfied our theoretical data that was determined previously. There was no cracking, splitting or tear-out of the composite link

section. We did notice a slight deformation of the Teflon bearings with the maximum load applied as seen in figure 17. Looking at the stainless steel rod after experimentation we noticed an insignificant deformation. Knowing that we far surpassed our design criteria the small deformation of the bearings and the rod were irrelevant. It is concluded that the bearing failure and tear-out failure tests were sufficient enough to define final design criteria for the link sections. These tests showed the bearings can withstand the force of estimated running conditions. Our analysis of the tear-out failure predicted a total force of 149. The testing conditions of 397 pounds prove our theoretical calculations were correct.



**Figure 17** Deformation of Teflon bearings

## **Impact Test**

### **Theoretical**

In calculating the theoretical loads that would be applied to the track such as in an impact we needed to assume certain constants. The first thing we did was assume the snowmobile has a constant velocity of 40 mph. Realizing that we cannot obtain the actual damping of the suspension we assumed a rigid suspension so as to find the highest possible impact load on the track. Another item under assumption is the object hits perpendicular to the track link section and glancing off so as to act like the track is immediately passing by the impact specimen. Not being able to calculate the exact

motion of the track over this object we assumed a direct impact and an immediate absorption of the impact or failure in the worst case.

Constant velocity of sled:

$$V_{\text{sled}} := 40\text{mph}$$

$$V_{\text{deflect}} := 35\text{mph}$$

$$V_{\text{sled}} = 58.667 \frac{\text{ft}}{\text{s}}$$

Consider impact case as glancing blow not full on, due to movement of track over surface.

$$\theta := 20\text{deg}$$

$$\Delta V := \sqrt{V_{\text{sled}}^2 + V_{\text{deflect}}^2 - 2 \cdot V_{\text{sled}} \cdot V_{\text{deflect}} \cdot \cos(\theta)}$$

$$\Delta V = 20.421 \frac{\text{ft}}{\text{s}}$$

The resultant vector of velocity would then be  $\Delta V$ .

$$m_{\text{sled}} := 685\text{lb}$$

$$t_1 := .04\text{s}$$

$$m_{\text{sled}} = 21.29\text{slug}$$

$$F_{\text{average}} := \frac{m_{\text{sled}} \cdot \Delta V}{t_1}$$

$$F_{\text{average}} = 1.087 \times 10^4 \text{ lbf}$$

This is the theoretical impact force that would be applied to the track under estimated running conditions.

## Experimental

### Introduction

Obtaining a good idea of what each composite link section could withstand under an impact was another deciding factor into the design. Knowing that the snowmobile encounters varied terrain and snow types the track needed to be tested for such impact capability. The group designed a testing apparatus that would be used to test the link section under various impacts. Our testing apparatus can be seen in figure 18. We were looking to apply a point load to the center point of the prototype section. This would be the best way to experimentally determine if a load applied during running conditions would fail. We knew that the most likely point of failure would be the very center of the track section due to its distance from each slider. This is where the load was applied for our testing.

## Experimental Apparatus and Instrumentation

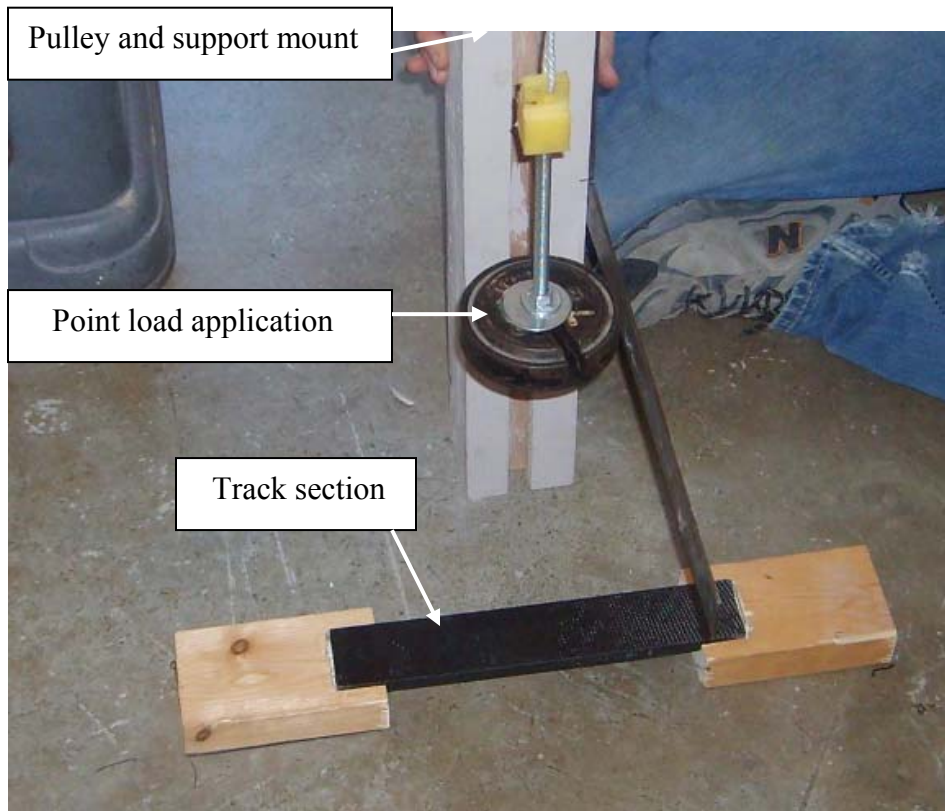

**Figure 18** Testing apparatus for Impact

### Procedure

We began by setting up a support and pulley system from which we would apply the point load. We fixed a pulley to a ten foot support beam and marked off every quarter foot in order to obtain impact data. Initially we used the one layer carbon fiber composite section in the support setup and began testing. Starting at a height of six inches above the track section and increasing at three inch increments, we mounted 2.988 pounds onto the point load apparatus. This process was repeated until the failure of the composite link section was reached. We applied the same load for each of the three composite samples increasing at the same interval for each sample.

### Results

Upon completion of the impact testing we determined that the one layer and two layer composite models were not going to suffice for any impact that may occur during estimated running conditions. The one-layer composite model only held up to an impact

at a height of six inches from the setup. At a height of six inches, applying 2.988 pounds is equivalent to an impact force of  $F_{\text{impact}}=23.43$  pounds force. Experimentally not much better, the second piece failed at a height of one and three quarter feet. With an immediate cracking of the carbon fibers it was determined that these two composite models could not be used in our design. The three layer composite model however was far more stiff and rigid, withstanding the impact from four and one half feet. The same load of 2.988 pounds applied from a height of four and one half height is equal to the force of  $F_{\text{impact}}=159.454$  pounds force. These values do not support the values of the theoretical numbers that we previously calculated. One thing that has not been refined is the time interval over which the impact acts. We can merely assume that the impact is going to glance off the track section or follow along the path of the inherent motion of the track. What all of this data shows is that the final design will need further composite analysis to find out the correct orientation, placement, and layering of the link sections.

Experimental Results:

$$m_{\text{exp}} := 2.988 \text{ lb}$$

$$v_{\text{exp}} := 17.17 \frac{\text{ft}}{\text{s}}$$

$$t_2 := .01 \text{ s}$$

$$m_{\text{exp}} = 0.093 \text{ slug}$$

$$F_{1\text{average}} := \frac{m_{\text{exp}} \cdot v_{\text{exp}}}{t_2}$$

$$F_{1\text{average}} = 159.458 \text{ lbf}$$

Ratio of Desired to Measured

$$\frac{F_{\text{average}}}{F_{1\text{average}}} = 68.164$$

This means that our experimental results show that the track needs to withstand 68 times the force that it underwent during testing to suffice during actual running conditions.

## Conclusion

Due to the complexity of build it was not practical to build complete test specimens for the impact tests. To simulate the final design we assumed the specimen to be a carbon fiber wrapped section of rubber stock. Once tested and modes of failure were observed, we did not feel the tested specimen was an accurate representation of the final design. The final design would incorporate an increased stiffness due to the addition of side rails and the stainless steel connection rods. Concluded from the experimental results the test

specimen failed at a force of impact much lower than the theoretical data showed. The theoretical calculations assume that the track is completely rigid and that the suspension is locked out (allowing no movement). A major constraint of the impact force is the time to stop the object from moving. The suspension of the snowmobile along with angular deflection will help reduce the impact force. The equations take into consideration the deflection angle but do not incorporate absorption of the impact through the suspension setup. Our test apparatus was setup to emulate a completely stiff suspension with a head on blow. The results from this test accurately depict the performance of the test specimen but do not fully represent the performance of the final design.

## **Slider/Track Interface Material Selection Testing**

### **Theoretical**

The track should be made from a track with a material that reduces the friction between itself and the sliders. The kinetic coefficient of friction,  $\mu_k$ , is more important to reduce due to its contribution to the energy loss being so much higher than that of the static coefficient of friction,  $\mu_s$ .

$$F_f = F_N * \mu_k$$

$$F_f = F_N * \mu_s$$

While the two surfaces are moving and in contact with each other the friction force is determined by  $\mu_k$ . However, while the sled is stopped the friction force is determined by  $\mu_s$ . The normal force,  $F_N$ , the force that is being applied to keep the surfaces together in this case is determined by the mass of the sled.

$$F_N = \text{mass} * g$$

Where mass in this experiment is the mass of object on top of the variable substance.  $g$  is the acceleration due to gravity,  $32.2 \text{ ft/s}^2$ .

## Experimental

### Introduction

In order to determine a material that would best suit the slider/track interface testing was done for multiple materials. In the current track design the interface is UHMW sliders and steel clips on the actual track. Due to our short design life we are looking into using different materials that decrease the slider/track interface friction. The idea behind this is that decreasing friction will decrease the loss of energy in the track. Before starting the testing we obtained a set of materials that would best suit our needs for short design life and decreased friction. These materials would include steel, aluminum, UHMW, and carbon fiber. Next we made an apparatus to test each material. This apparatus can be seen in figure 19. Using this apparatus we tested each material for the best possible choice.

### Experimental Apparatus and Instrumentation

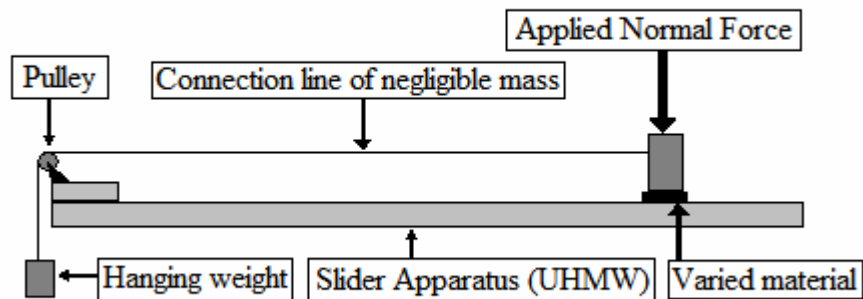

Figure 19 Slider/Track Interface testing apparatus

### Procedure

Beginning with the apparatus that is shown in figure 19 we set up on a level surface and obtained all materials to be tested. These materials were cut into a one inch by one inch square. The test material was then set on the UHMW and a load was applied to the material in the normal direction. We used a lightweight connection line and ran it over the pulley down to the weight cup. Weight was placed into the cup and the test material

was held without movement until the weight was stable. The first process was to find the coefficient of static friction for each material. When releasing the test specimen we found the applied weight at which an immediate acceleration was reached. This would give us a way to calculate the coefficient of static friction. The process was repeated for each test specimen. In order to find the coefficient of kinetic friction less weight was placed into the weight cup and the test specimen was given a slight nudge. Doing this gives the specimen an initial velocity and we can then determine the weight that gives the specimen constant velocity. This process was also repeated for all specimens.

### **Results and Conclusion**

Through experimental data it was determined that the material with the best coefficient of friction for the slider/track interface was the carbon fiber composite. The coefficient of static and kinetic friction was  $\mu_s = .19$  and  $\mu_k = .16$  respectively. Under steady conditions without snow and dirt this would be a good material to use. The problem with the carbon fiber composite is that the resin would begin to wear easily with dirt and debris sliding between the sliders and the track. This would cause corrosion of the track sections and therefore failure of the track. It was also determined that an interface made up of entirely UHMW would not suffice. If the slider/track interface encountered dirt or external particles of any sort the UHMW would wear and not be able to form a smooth interface again. The best possible material for the slider/track interface is the steel. Steel and UHMW interface has coefficients of friction of  $\mu_s = .27$  and  $\mu_k = .23$ . The steel will ultimately keep the sliders smooth and not wear as quickly as the composite or UHMW.

## Appendix A: Annotated Bibliography

Ageikin, Ia. S ; *Off-the-road Wheeled and Combined Traction Devices*. New Delhi: Amerind Publishing Co. Pvt. Ltd., 1987.

Off-the-road Wheeled and Combined Traction Devices gives a very in depth look into the reaction of soils with wheeled vehicles. It gives all the aspects of wheel to soil interaction that need to be taken into consideration while designing and calculating the forces acting on a wheel. These equations and information are very helpful in stating that the reactions of snow and soils are analogous in many ways. It however does not go very in depth with soil interaction between a tracked vehicle and soils. There are some very interesting ideas presented and calculations given but for the most part this book is geared more towards tread design for wheels and wheel based vehicles.

Bankston, Brent A.; Keating, E. Michael. "The comparisons of polyethylene wear in machined vs. molded polyethylene." Report on comparisons in Hutchinson, MN 1999.

This report helped to gain an understanding as to how molding vs. machining the UHMW and all polyethylene's was different. It really gave information that pertained to why this material was so strong under low temperature conditions as well as telling how the best option for the sliders is what is used now. That is the UHMW polyethylene. It is great under low temperatures; slow wear conditions, low friction of coefficient and high abrasion resistance.

Garner, John. "Understanding Horsepower Loss Through Drive Train." <http://www.superstang.com/horsepower.htm>. 4/2/2007

This article was used as a reference for basic engine characteristics that relate to efficiency. From this website the group could better draw conclusions about the how the losses in efficiency are distributed among the mechanical components of an engine and drive train.

Hyer, Michael W., Stress Analysis of Fiber Reinforced Composite Materials. Boston: WCB McGraw Hill, 1998.

This text book was the primary source for all of our theoretical analysis of the composite materials used to construct the links. The book provided valuable information regarding the stress-strain analysis and the failure mode of fiber-reinforced composites which was extremely useful in our design analysis. The text also provided useful material properties and general information on composite material and its physical behavior

Ihla Communications. <http://www.tracksusa.com/faq.html>. Bruce Vruwink, 2003.  
10/07/2006

This is a commercial site answering questions about pitch and profile heights (lug heights) of tracks. It gives a good comparison of the different tracks, but says that tracks are made for different snow conditions. The consumer should think of the snow they travel in most often and buy a track accordingly.

Instron, Materials Testing Solutions, [http://www.instron.us/wa/home/default\\_en.aspx](http://www.instron.us/wa/home/default_en.aspx),  
September 26<sup>th</sup>, 2006.

Instron gave all types of testing methods for a very wide variety of materials. It gave a brief description of all types of testing methods and standards for rubbers and other materials that may be considered in designing a track. Among the tests described were many well known tests for rubbers and other pliable materials. Much of the focus being put on the Shore testing methods, the ASTM and ISO standards that testing must follow.

Kanarart, Amnat. "Modeling and Simulation of a Multi-Unit Track Vehicle." Masters Thesis submitted to the Virginia Polytechnical Institute and State University. 28 Sep. 1999.

This source addresses the concept of track terrain interaction similarly some of the other articles and expresses its importance in creating an accurate theoretical model for the vehicles motion. There is an outline of modeling the motion using MatLab that could prove to be a helpful guide for creating our own similar simulation for the snowmobile track if we decide something like that will be useful in our analysis.

LaMunion, Steven, "Drag Racing Story of the Day! How Do Snowmobiles Drag Race on Asphalt?" <http://www.draglist.com/stories/SOD%20Nov%202000/SOD-111300.htm>.  
4/30/2006. Copyright Bilden Enterprises, Inc. 2007

This site was used mostly for its photography. However it did give good advice on reduction of drag and friction for snowmobile riders, including the addition of bogey wheels throughout the suspension system.

Le, Anh Tuan. "Modeling and Control of Tracked Vehicles." Phd. Thesis. Department of Mechanical and Mechatronic Engineering, University of Sidney. 26 January 1999.

The thesis set forth by Le is a very comprehensive look at tracked vehicles and of modeling their motion. Included is an in depth process for estimating vehicle behavior that seem to be beyond the scope of our work on this track but is an interesting supplement to the mechanical models he derives. There is a very large section of the 222 pages that deals with controls that are only relevant to a track

that is involved in steering. The article is a good general source of track-soil interaction modeling.

Ma, Zheng-Dong; Perkins, Noel C. "Modeling of Track-Wheel-Terrain Interaction for Dynamic Simulation of Tracked Vehicle Systems." Proceedings of ASME Engineering Technical Conferences. September 1999.

This dissertation, as the title describes, focuses on the Track-Wheel-Terrain interaction primarily. The author's model is derived very clearly and simply. This paper is concise and very easy to follow and understand. Using finite element methods, the author examines the effect of different terrains on different types and configurations of the track. Again, an article such as this could be useful in deriving our own equations of motion for the snowmobile track.

Merl Ltd. Research Consultants in Polymer Engineering and Materials Selection, <http://www.merl-ltd.co.uk/>, September 28<sup>th</sup>, 2006.

Merl Ltd. Provided a very helpful list of possible rubbers that can be used in many situations. With each type of rubber described they provided temperature ranges, pressure ranges and resistance to certain chemicals. Providing a good basis for which rubbers may apply to our situations and which rubbers we should veer from. Also gave a good basis for what combinations of rubbers would be most effective.

Nave, Rod Dr., <http://hyperphysics.phy-astr.gsu.edu/hbase/duck.html#c1>. 4/3/07, placecountry-regionGeorgia State University

The hyper physics web site is a web site based for teacher's but is currently used by Universities world wide. We used this web site to learn more about the physics of impacts and collisions. The site has equations readily available and is easily navigable.

Norton, Robert L., *Machine Design An Integrated Approach*. New York, Pearson Education, 1999.

Machine Design contains all necessary equations to determine which bearings, gears and other crucial mechanical parts of a system we should use. Shafts and rollers are also included with equations for factors of safety and design criteria. Through the equations given and the information provided of materials and their selection, a proper system can be setup and calculated to be sure that our track components will last their design life and also be safe for the rider.

Olé communication. [http://www.camoplast.com/en/tracksystem/replacementtracks\\_snowmobile\\_all.php](http://www.camoplast.com/en/tracksystem/replacementtracks_snowmobile_all.php) Copyright 2006, CAMOPLAST INC. 9/25/2006

This site helped give an understanding of the differences between tracks and how those differences affect the tracks performance. I was able to use this site to compare different track dimensions to their advertised benefits.

SAE International. <http://students.sae.org/competitions/snow/>. Copyright 2006.  
9/30/2006

This is the SAE clean snowmobile competition site. It gave a statistical history of previous competitions as well as information on the competition meant for this year. I also found out a little about the companies sponsoring the event.

Sandu, Corina and Freeman, Jeffery S. "Connectivity Algorithm for an Extended Rubber-band Track Model." *Heavy Vehicle Systems. A Series of the Int. J of Vehicle Design*. Vol. 9, No. 4, pp 334-355.

This essay and study outlines a mathematical model for a track best described as a tank track or construction vehicle. Though the application of the track is focused on a much heavier vehicle, the authors derive some dynamic analyses that could be directly applied to a model of the snowmobile track and some that could be applied after slight alteration. There is no mention of or example of track interaction with snow but there are several actual tests that were performed to ascertain critical information about track-terrain interaction.

Up North Sports. <http://www.upnorthsports.com/Sites/upnorth/Include/faq.tml> © 1999 - 2006. 10/07/2006

This site gave information on general snowmobiling activity. I used it for the information given on studs. It states that there is no exact solution but that installing too few studs into a track can be more harmful to the track than helpful. This is because studs put holes into the track and with any slipping the studs will catch and tear at the track.

Yong, Raymond ; Fattah, Ezzat A.; Skiados, Nicolas. *Vehicle Traction Mechanics*. New York: Elsevier Science Publishers B.V., 1984.

Vehicle Traction Mechanics is a very good introduction and reference into the area of traction, especially in tracked vehicles. The book goes over a great number of aspects of track construction and design and then outlines multiple methods of analyzing the effect of these aspects. It is the primary source of this brief summary on track efficiency and performance and was vital in helping me understand the different areas that the group will need to examine and test with our own design.

## Appendix B: Sample Calculations

### Efficiency Analysis

$$\begin{aligned} \text{mass} &:= 685\text{lb} + 180\text{lb} & \text{mass} &= 865\text{lb} \\ \text{engine} &:= 80\text{hp} & \text{engine} &= 5.966 \times 10^4 \text{ W} \end{aligned}$$

Current sled accelerates at a rate of 0-60mph in 5.5s if we assume a constant acceleration:

$$t := 5.0\text{sec} \quad V_0 := 0\text{mph} \quad V_1 := 60\text{mph}$$

$$\text{track} := 0.5 \cdot \text{mass} \cdot V_0^2 + 0.5 \cdot \text{mass} \cdot (V_1^2) \quad X_0 := 0\text{ft}$$

$$\begin{aligned} \text{track} &= 189.271\text{s hp} \\ \text{acceleration} &:= \frac{V_1 - V_0}{t} \end{aligned}$$

$$\text{distance} := \frac{(V_0 + V_1) \cdot t}{2} \quad \text{distance} := 0.5 \cdot \text{acceleration} \cdot t^2 \quad \text{distance} = 67.056\text{m}$$

$$\text{force} := \text{mass} \cdot \text{acceleration} \quad \text{force} = 473.176\text{bf}$$

$$\text{work} := \text{force} \cdot \text{distance} \quad \text{work} = 1.411 \times 10^5 \text{ J}$$

$$\text{energy} := \frac{\text{work}}{t} \quad \text{energy} = 2.823 \times 10^4 \text{ W}$$

If the drive system were working at 100% efficiency in 5.5 secs the sled would be traveling at an approximate rate calculated below:

The variables that stayed the same: Mass,  $V_0$ ,  $t$ , and  $X_0$

$V_1$  was found, through a series of reiterations of the above equations, to be:

$$V_t := 91.482 \frac{\text{ft}}{\text{sec}}$$

The efficiency of the drive train system can be found using the following:

$$\text{eff} := \frac{\text{energy}}{\text{engine}} \quad \text{eff} = 47.318\%$$

## Bearing Failure Analysis

L1 := 0.5in                      r = radius of curvature around the corner

L2 := 0.125in

D1 := 0.125in

$$r := \frac{1}{80} \cdot \text{in}$$

D2 := 0.25in

D3 := 0.375in

Teflon Properties:

maxstrain := 0.5                      1500 to 3000

tensilestrength := 11MPa              tensilestrength = 1.595ksi

Etef := 350ksi

Stress concentration factor was determined by Robert L. Norton's machine Design text, A and b are constants found in appendix E

$A := 0.9383$                        $b := -0.2575$

$$K_t := A \cdot \left( \frac{r}{D_2} \right)^b \quad K_t = 2.03$$

determination of stress, Cload = 1.0 Csize = determined below,  
Ctemp = 1, Csurf = 1, Creli = 0.753

$$C_{size} := 0.869 \left( D_2 \cdot \text{m}^{-1} \right)^{-0.097}$$

Sm1 := 0.9tensilestrength

Sm := Csize·0.753Sm1

Sm = 1.535 × 10<sup>3</sup> psi

Sm = 1.058 × 10<sup>7</sup> Pa

P := 1lbf

$$R := \frac{L_1 \cdot P}{L_1 - L_2}$$

$$V_{max} := -R \cdot (L_1 - L_2) + P \cdot (L_1 - L_2)$$

Abearing := D1·L1

$$M_{max} := \frac{-R}{2} \cdot (L_1 - L_2) + \frac{P}{2} \cdot (L_1 - L_2)$$

$$\tau := \frac{P}{A_{bearing}}$$

$$I := \frac{\pi}{64} \cdot (D_2^4 - D_1^4)$$

$$c := \frac{D_3}{2}$$

All the C's are dimensionless numbers they are meant to reduce the value of Sm due to the situation the material is being placed in vs. an experimental standard set forth. The C's are known as correction factors. They were determined using Robert L. Norton's book Machine Design: an Integrated Approach.

$$\text{Sigx} := \frac{\text{Mmax} \cdot c}{I} \quad \text{sigy} := 0 \quad \text{tauy} := 0 \quad \text{taux} := \text{tau}$$

$$\underline{\underline{I}} := 47 \text{ lbf} \cdot \text{in}^4 \quad \text{sigz} := 0 \quad \text{tauz} := 0$$

$$\underline{\underline{W}} := 2 \text{ in}$$

$$r := 3.5 \text{ in}$$

$$t := 0.5 \text{ in} \quad \text{Erub} := 2 \text{ ksi} \quad \text{Ecomp} := 20.0 \cdot 10^6 \cdot \text{psi}$$

$$\underline{\underline{R}} := r + \frac{t}{2} \quad \underline{\underline{c}} := \frac{W}{2}$$

$$\text{sigmaprime} := \left[ \frac{(\text{Sigx} - \text{sigy})^2 + (\text{sigy} - \text{sigz})^2 + (\text{sigz} - \text{Sigx})^2 + 6 \cdot (\text{taux}^2 + \text{tauy}^2 + \text{tauz}^2)}{2} \right]^{\frac{1}{2}}$$

$$\text{sigmaprime} = 70.836 \text{ psi} \quad \text{sigma} := Kt \cdot \text{sigmaprime}$$

This  $S_m$  is meant for determining the load possible for one cycle  
the slope of the S - N diagram for Teflon is

$$S_m = 1.535 \times 10^3 \text{ psi}$$

$$\text{sigma} = 143.799 \text{ psi}$$

## Strain Energy Analysis

First we find delta the deflection of the rubber / composite around the bogey wheel

$$\theta := \frac{W}{R} \quad \text{angle} := \frac{c}{R} \quad \text{angle} = 15.279\text{deg}$$

$$\delta := R - R \cdot \cos(\text{angle}) \quad \delta = 0.133\text{in}$$

$$\theta = 0.533\text{rad}$$

maximum deflection for the sections is given by delta

The composite sections still have the possibility of bending just as far but the increased modulus of elasticity keeps the sections from flexing

$$\phi := 90\text{deg} - \theta \quad \phi = 59.442\text{deg}$$

The tension from the leading section of track will be pulling the following section at an angle of 59.442 degrees off the vertical. The bending component of the force is going to be perpendicular to the section's width and be calculated with the previously found data

$$F_b := T \cdot \cos(\phi) \quad r_i := 0.125\text{in}$$

$$F_b = 239.459\text{lbf} \quad r_o := 0.5\text{in}$$

The stress on the section that will cause bending is due to this force fraction of the total force.

$$I := \frac{W^3 t}{12} \quad \text{centroid} := \frac{(c - 0.5756\text{in}) \cdot \pi \cdot \frac{t^2}{8} - (c - 0.5\text{in}) \cdot (\pi \cdot r^2) + c \cdot t \cdot \left( \frac{c - 0.5\text{in}}{2} \right)}{c \cdot t - \pi \cdot (.125\text{in})^2 + \pi \cdot \frac{t^2}{8}}$$

The composite section will bend but not nearly as much as the rubber track already does

The stress on the composite section is found with this formula for thick walled cylinders

$$\text{centroid} = -34.741\text{in}$$

$$\sigma := Fb \cdot c \cdot \frac{\text{centroid}}{I} \quad I = 0.333 \text{in}^4$$

$$\text{strain} := \frac{\sigma}{E_{\text{comp}}} \quad \sigma = -2.496 \times 10^4 \text{ psi}$$

$$\text{strain} = -1.248 \times 10^{-3}$$

$$\text{deflection} := \text{strain} \cdot c$$

$$\text{deflection} = -1.248 \times 10^{-3} \text{ in}$$

U the strain energy for the composite is determined below

$$U := \left( E_{\text{comp}} \cdot \text{deflection}^2 \right) \cdot \frac{c \cdot t - \pi (0.125 \text{in})^2 + \pi \frac{t^2}{8}}{2 \times 15}$$

$$U = 220.068 \frac{\text{lb} \cdot \text{in}^3}{\text{s}^2}$$

The deflection of the rubber is found here by adding the curve of that the rubber makes and adding the the deflection due to the tension:

$$A_{\text{rub}} := \left( \frac{t}{2} \right) \cdot c$$

Spring coefficient of rubber over the same length of section as used in the composite calculation

$$k_{\text{rub}} := \frac{E_{\text{rub}} \cdot A_{\text{rub}}}{c} \quad \text{deflection}_{\text{rub}} := \frac{T}{k_{\text{rub}}}$$

$$U_{\text{r}} := \frac{E_{\text{rub}} \cdot A_{\text{rub}} \cdot \text{deflection}_{\text{rub}}^2}{2 \cdot 15} \quad U_{\text{r}} = 5.71 \times 10^3 \frac{\text{lb} \cdot \text{in}^3}{\text{s}^2}$$

The difference in strain energies is the difference between the values of  $U_{\text{r}}$  and  $U$

$$\text{factor} := \frac{U_{\text{r}}}{U} \quad \text{factor} = 25.947$$

## Composite Analysis

### Engineering Properties

$$\begin{aligned}\epsilon_1 &= 155 \cdot (10^9) \text{ psi} \\ \epsilon_2 &= 12.1 \cdot (10^9) \text{ psi} \\ G_{12} &= 4.4 \cdot (10^9) \text{ psi} \\ \nu_{12} &= .248 \\ \nu_{21} &= \nu_{12} \cdot (E_2/E_1) \\ Q_{11} &= E_1 / (1 - (\nu_{12} \cdot \nu_{21})) \\ Q_{12} &= (\nu_{12} \cdot E_2) / (1 - (\nu_{12} \cdot \nu_{21})) \\ Q_{22} &= E_2 / (1 - (\nu_{12} \cdot \nu_{21})) \\ Q_{66} &= G_{12}\end{aligned}$$

Number of Layers  $N=3$

Layer Thickness  $t_1=t_2=t_3= 0.00015$  in

### Layer Orientation Angles

$$\begin{aligned}\text{Layer 1: } &45^\circ \\ \text{Layer 2: } &-45^\circ \\ \text{Layer 3: } &45^\circ\end{aligned}$$

### Applied Forces

$$\begin{aligned}N_x &= 102400 \text{ N} \quad \text{Note: with safety factor of 2} \\ N_y &= 0 \\ N_{xy} &= 0\end{aligned}$$

### Allowable Strains

$$\begin{aligned}\epsilon_{xAlw} &= .006 \\ \epsilon_{yAlw} &= .006 \\ G_{xyAl} &= .006\end{aligned}$$

### Allowable Stresses According to Material Specification

$$\begin{aligned}\sigma_{1c} &= 1500 \cdot (10.^6.) \text{ Pa} \\ \sigma_{1t} &= -1250 \cdot (10.^6.) \text{ Pa} \\ \sigma_{2c} &= 50 \cdot (10.^6.) \text{ Pa} \\ \sigma_{2t} &= -200 \cdot (10.^6.) \text{ psi} \\ \tau_{12f} &= 100 \cdot (10.^6.) \text{ psi}\end{aligned}$$

**The first step is to establish the Reduced and Transformed Reduced stiffness matrices.**

Reduced Stiffness Matrix

$$S := \begin{pmatrix} Q_{11} & Q_{12} & Q_{13} \\ Q_{21} & Q_{22} & Q_{23} \\ Q_{31} & Q_{32} & Q_{33} \end{pmatrix}$$

Transformed Reduced Stiffness Matrix

$$Q\text{Bar} := \begin{pmatrix} Q_{11} & Q_{12} & Q_{13} \\ Q_{21} & Q_{22} & Q_{23} \\ Q_{31} & Q_{32} & Q_{33} \end{pmatrix} \begin{pmatrix} m^2 & n^2 & -2mn \\ n^2 & m^2 & 2mn \\ mn & -mn & -n^2 \end{pmatrix} \quad m := \cos(\theta) \quad n := \sin(\theta)$$

**Once these matrices are established for each layer the laminate stiffness matrix can be calculated. (N is the layer number)**

$$A := \begin{pmatrix} A_{11} & A_{12} & A_{13} \\ A_{21} & A_{22} & A_{23} \\ A_{31} & A_{32} & A_{33} \end{pmatrix}$$

$$A_{ij} := \sum_{k=1}^N Q\text{Bar}_{ijk} (z_k - z_{k-1})$$

**With the Laminate Stiffness the Engineering Properties in the principle system of the whole laminate can be calculated**

$$E_x = (A_{11} \cdot A_{22} - (A_{12})^2) / (A_{22} \cdot \text{LAMTHKN})$$

$$E_y = (A_{11} \cdot A_{22} - (A_{12})^2) / (A_{11} \cdot \text{LAMTHKN})$$

$$G_{xy} = A_{66} / \text{LAMTHKN}$$

$$\nu_{xy} = A_{12} / A_{22}$$

$$\nu_x = A_{12} / A_{11}$$

The inverse laminate stiffness values can be calculated as follows

$$\begin{aligned} a_{11} &= A_{22}/((A_{11} \cdot A_{22}) - (A_{12}^2)) \\ a_{12} &= -A_{12}/((A_{11} \cdot A_{22}) - (A_{12}^2)) \\ a_{22} &= A_{11}/((A_{11} \cdot A_{22}) - (A_{12}^2)) \\ a_{66} &= 1/A_{66} \end{aligned}$$

With these inverse values the strains due to the applied load can be found

$$\begin{aligned} \epsilon_x &= a_{11} \cdot N_x + a_{12} \cdot N_y \\ \epsilon_y &= a_{12} \cdot N_x + a_{22} \cdot N_y \\ \gamma_{xy} &= a_{66} \cdot N_{xy} \end{aligned}$$

As long as these strains are below the allowable strain for the laminate, the calculations can continue. The next step is to calculate the stress in each layer for in the global and principle coordinate systems. ('I' indicates the layer number)

**Global:**

$$\begin{aligned} \sigma_x(I) &= Q_{11} \text{Bar}(I) \cdot \epsilon_x + Q_{12} \text{Bar}(I) \cdot \epsilon_y + Q_{16} \text{Bar}(I) \cdot \gamma_{xy} \\ \sigma_y(I) &= Q_{12} \text{Bar}(I) \cdot \epsilon_x + Q_{22} \text{Bar}(I) \cdot \epsilon_y + Q_{26} \text{Bar}(I) \cdot \gamma_{xy} \\ \tau_{xy}(I) &= Q_{16} \text{Bar}(I) \cdot \epsilon_x + Q_{26} \text{Bar}(I) \cdot \epsilon_y + Q_{66} \text{Bar}(I) \cdot \gamma_{xy} \end{aligned}$$

**Principle:**

$$\begin{aligned} \sigma_1(I) &= (m^2) \cdot \sigma_x(I) + (n^2) \cdot \sigma_y(I) + (2 \cdot n \cdot m) \cdot \tau_{xy}(I) \\ \sigma_2(I) &= (n^2) \cdot \sigma_x(I) + (m^2) \cdot \sigma_y(I) + (-2 \cdot n \cdot m) \cdot \tau_{xy}(I) \\ \tau_{12}(I) &= (-m \cdot n) \cdot \sigma_x(I) + (m \cdot n) \cdot \sigma_y(I) + ((m^2) - (n^2)) \cdot \tau_{xy}(I) \end{aligned}$$

The last calculation needed for the Tsai Wu failure criterion is the material constant F, which are base on the compressive and tensile stress ratings

$$\begin{aligned} F_1 &= (1/\sigma_{1t}) + (1/\sigma_{1c}) \\ F_{11} &= -1/(\sigma_{1t} \cdot \sigma_{1c}) \\ F_2 &= (1/\sigma_{2t}) + (1/\sigma_{2c}) \\ F_{22} &= -1/(\sigma_{2t} \cdot \sigma_{2c}) \\ F_{66} &= (1/\tau_{12f})^2 \end{aligned}$$

Using these values, the Tsai Wu Criterion Equation can be computed. If the result is equal to 1, then there is failure in the layer, and if it is less than one then there is no failure in the layer.

$$F_1 \cdot \sigma_1 + F_2 \cdot \sigma_2 + F_{11} \cdot \sigma_1^2 + F_{22} \cdot \sigma_2^2 + F_{66} \cdot \tau_{12}^2 - \sqrt{F_{11} \cdot F_{22}} \cdot \sigma_1 \cdot \sigma_2 := 1$$

After running the program with the design conditions, it was discovered that there is no failure.

## Appendix C: Testing Data

Material	coefficient of friction	Normal Force (lb)	Pulling Force (lb)	coefficient
UHMW	$\mu_k$	0.324	0.118	0.36
	$\mu_s$	0.498	0.128	0.26
	$\mu_k$	0.654	0.228	0.35
	$\mu_s$	1.004	0.228	0.23
Aluminum polished using 300 grit sandpaper	$\mu_k$	0.424	0.128	0.30
	$\mu_s$	0.346	0.094	0.27
	$\mu_k$	1.228	0.248	0.20
	$\mu_s$	1.228	0.286	0.23
Steel polished using 300 grit sandpaper	$\mu_k$	0.5	0.12	0.24
	$\mu_s$	0.5	0.136	0.27
	$\mu_k$	0.72	0.162	0.23
	$\mu_s$	0.72	0.202	0.28
Carbon Fiber composite	$\mu_k$	0.312	0.05	0.16
	$\mu_s$	0.312	0.062	0.20
	$\mu_k$	0.532	0.084	0.16
	$\mu_s$	0.532	0.094	0.18